

sisis[®]

MULTISLIT 1200

INSTRUCTION MANUAL

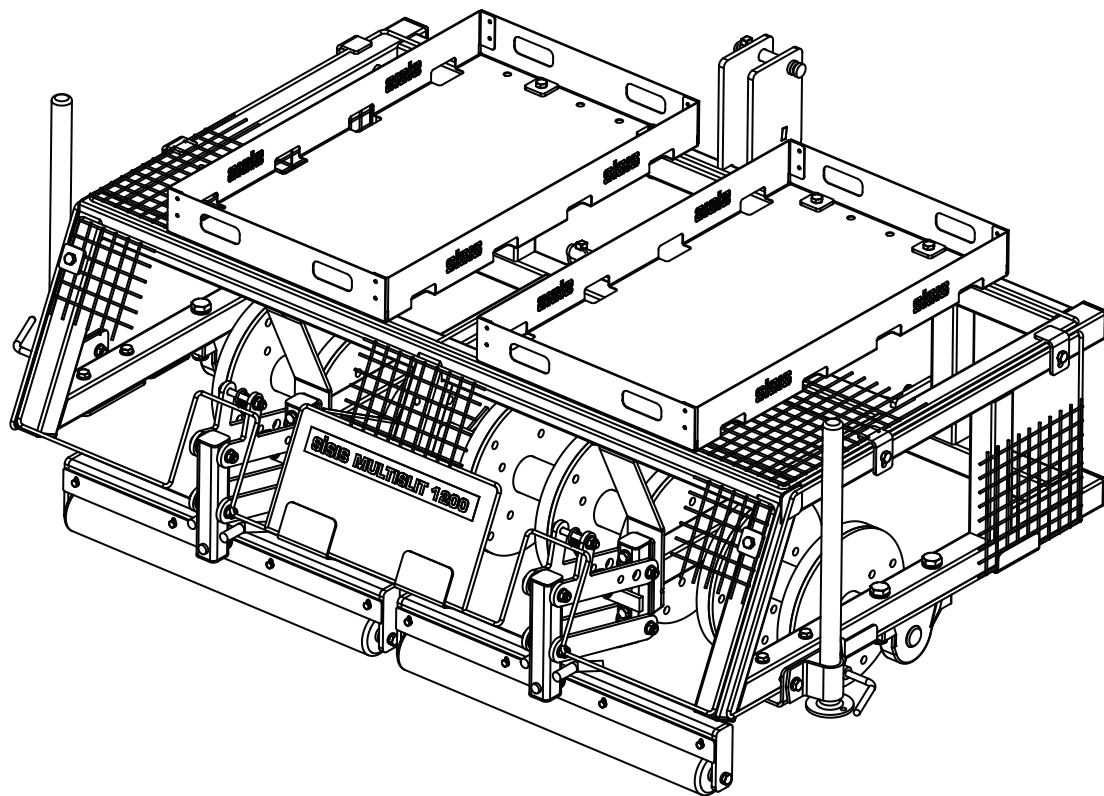

SISIS, Ashbourne Road, Kirk Langley, Derbyshire, DE6 4NJ, England.

Tel: +44 (0) 1332 824 777 | Fax: +44 (0) 1332 824 525 | Email: info@sisis.com | www.sisis.com

A division of Howardson Ltd. - a proudly British company
Company reg no 641526 - Vat No GB 345 9918 12

SP20033_REV_0
05/13



NOTE

MAKE A NOTE OF THE SERIAL NUMBERS OF YOUR MACHINE & ENGINE AND ALWAYS QUOTE THEM IN ANY COMMUNICATION WITH PERSONNEL AT DENNIS.

MACHINE SERIAL NUMBER

Introduction

The **SISIS Multislit 1200** is virtually maintenance-free, and tines can be replaced should they become worn.

It is advisable to read the instructions carefully. Proper care and attention will enable the machine to give a continuous, satisfactory, and reliable service.

In the case of any difficulty, or if further information or advice is required, our Service Department is always at your call. In the interests of speed and accuracy of information please quote the serial number of the machine when making enquiries.

For the machine, this is to be found on a plate attached to the front of the frame. We suggest you write the numbers above.

Contents

	Page
Serial Numbers.....	2
Introduction.....	2
Technical Data.....	2
Important Safety Instructions.....	3
Operating Instructions	4 - 6
Parts Listings.....	7

Technical Data

Model	Multislit 1200
Model Reference	MS/1200
Length (mts)	1.05
Width - Overall (mts)	1.65
Weight (Kg)	175
Number of Tines	32
Part Number - 152 x 3	D6951
Part Number - 152 x 3	D7493
Part Number - 152 x 3	D6998
Tractor Requirement	14.9 kW
Tines	6951 / 7493 / 6998
Coverage (Without Headlands)	12.8 km/h - 8mph 1,698m ² - 2020yds ²



CAUTION

READ THE INSTRUCTIONS CAREFULLY AND ALSO THE SEPARATE INSTRUCTION DETAILS ON THE ENGINE.

ALWAYS

- Read the operating instructions carefully and understand the controls before commencing work.
- Be extra careful to avoid spillage, when using petrol or diesel fuel. **DANGER** no smoking or naked lights
- Use safety guards and make sure they are correctly in position. They are supplied for your protection
- Visually check machines before starting work for damage or wear to working parts such as blades, tines or loose fasteners
- Respect powered machines. Always keep hands and feet clear of moving parts and remember that tine cylinders or drums can continue to rotate even after the power unit is switched off
- Switch off the power before making adjustments or repairs and never lift or carry a machine whilst any parts are Moving

EYE PROTECTION

In dry, dusty or windy conditions it may be necessary to wear eye protection to protect your eyes from flying debris.



CAUTION

PLEASE READ THESE OPERATING INSTRUCTIONS CAREFULLY BEFORE COMMENCING WORK.

We want you to obtain the best performance from this machine. If you have any difficulty in carrying out the following instructions please contact SISIS direct or your local SISIS Territory Manager or SISIS Dealer.

OPERATING PRINCIPAL

The SISIS **Multislit 1200** is a tractor mounted deep slitter having a slitter shaft rotating on sealed bearings, for both out-field and fine turf.

The tines are arranged in a helix pattern to run smoothly across the ground and are made from a hardened carbon steel, standard penetration depth is 155mm or 205mm with the long tines installed.

The tines are mounted onto to the tine shaft faceplates.

The Multislit 1200 mounts directly to the tractor 3 point mounting with the supplied pins.

The Multislit 1200 is fitted with stand legs at the front and sides. These should be retracted and locked when in use (**See Figure 1**) and lowered and locked before removing the Multislit 1200 from the tractor (**See Figure 2**).

This will ensure the tines do not contact the ground when on hard standing and protect the tines from damage.

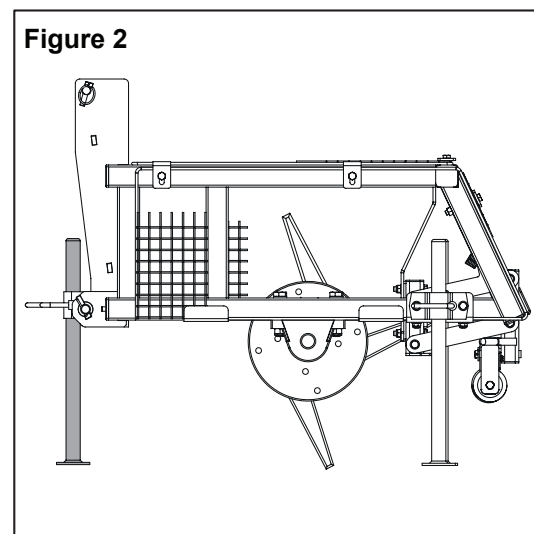
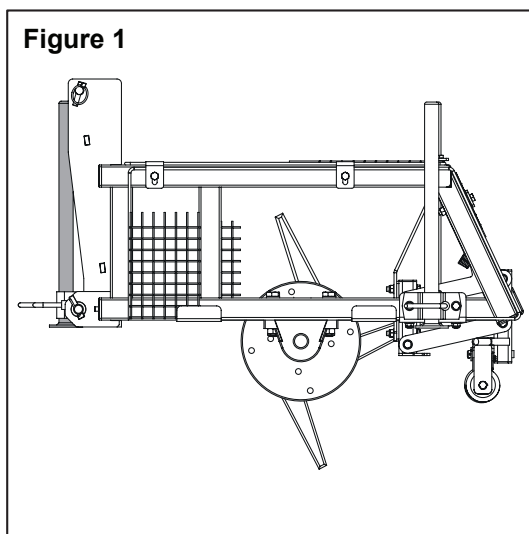

FITTING TINES

When fitting the tines it is important that they are fitted in the correct position in relation to the forward motion
(See Figure 3)

TINE POSITIONING

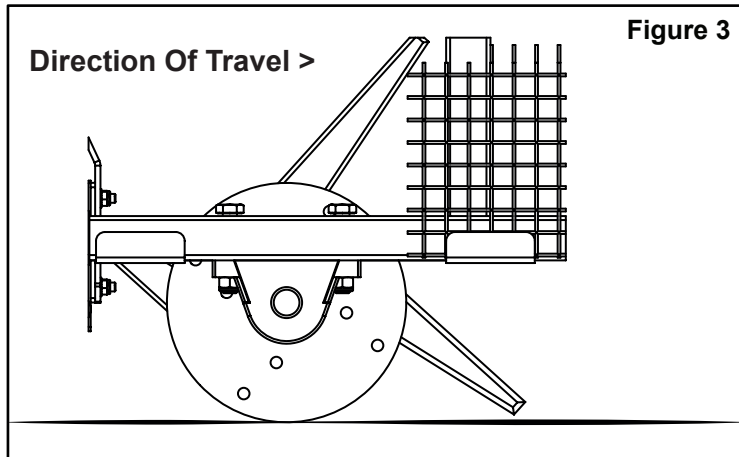

TINES

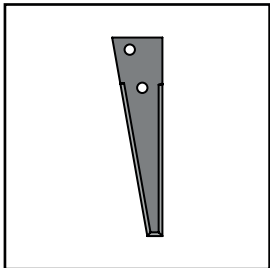

D6951 - 152mm x 3mm thick, sharpened tine for fine turf and quality outfield turf.
Set of 40

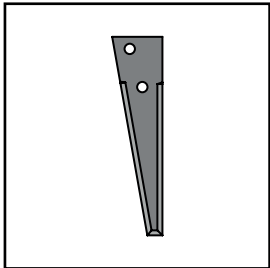

D7493 - 152mm x 8mm thick, heavy duty tines for use where shallow soil depth prevails.
Set of 40

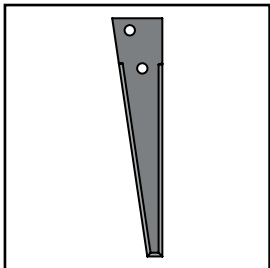

D6998 - 203mm x 3mm thick, sharpened tine fine turf only, should only be used in good ground conditions, generally after previous extensive use of D6951 tines.
Set of 40

CONNECTION TO THE TRACTOR

Attach the Multislit to the tractor hydraulic linkage and secure with linch pins.

Adjust the tractor top link, ensuring that the implement is vertical and the base of the guard is parallel to the ground.

Standing at the rear of the machine, check that the implement frame is horizontally square to the surface and adjust the tractor linkage arms if required.

OPERATION

Use low gear on the tractor to give a speed of no more than 4mph. Lower the implement into the ground as you move forward. Keep moving forward as you raise the implement out of the ground to prevent plucking.

LUBRICATION

WEEKLY - Grease Bearings as shown in **Figure 4**.

- Oil pivot points on Rollers as shown in **Figure 5**.

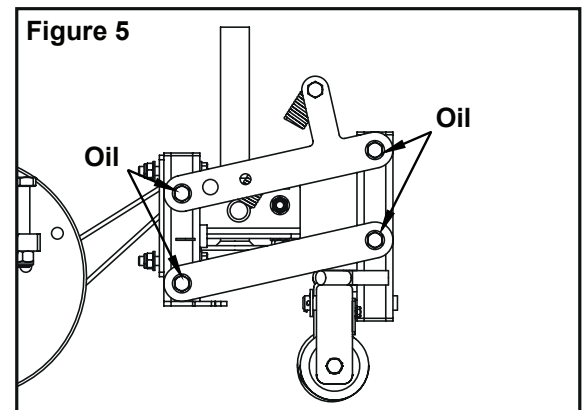
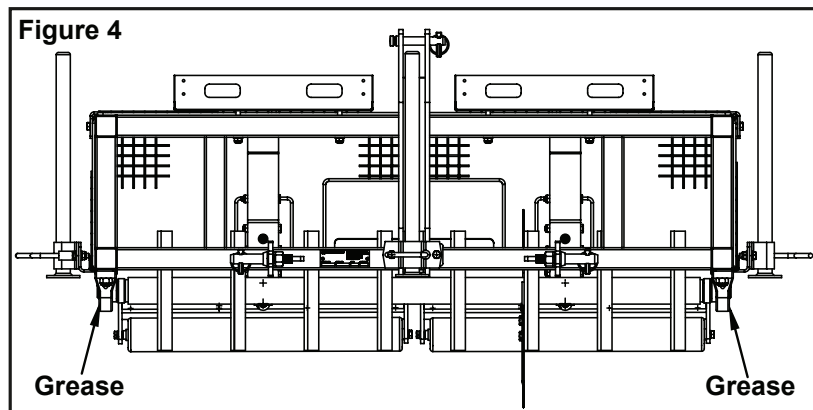

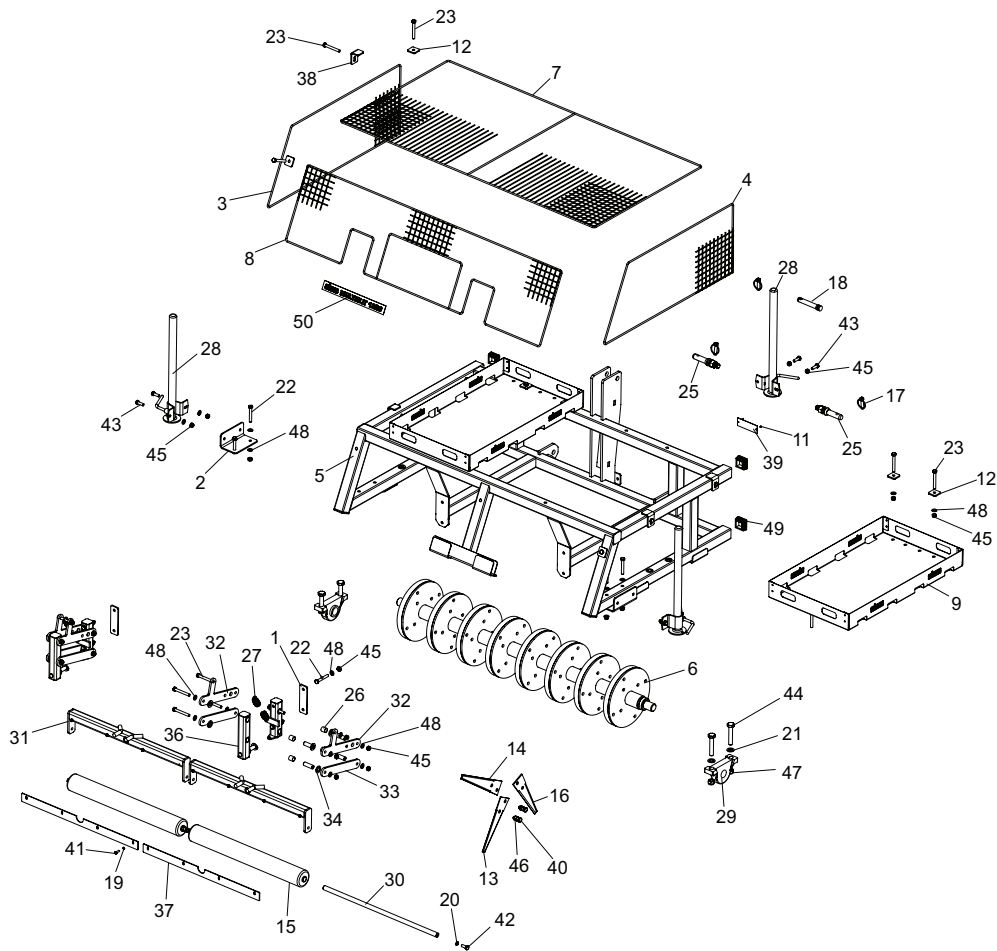

1.01

Multislit 1200

Item No.	Part No.	Description	Quantity	Item No.	Part No.	Description	Quantity
1	401510	Platwasher Roller	2	38	F34904	Guard Clamp	4
2	401511	Bracket Drop Leg	2	39	F36000	Serial No Plate (Sisis)	1
3	401513	Multislit Side Cover LH	1	40	SP01065	Hex Set Screw M12 x 30	2
4	401517	Multislit Side Cover RH	1	41	SP01028	Hex Set Screw M6 x 20	8
5	401522	Multislit 1200 Frame WA	1	42	SP01035	Hex Set Screw M10 x 25	4
6	401526	Slitter Shaft 1200 WA	1	43	SP01105	Hex Set Screw M10 x 30	6
7	401528	Multislit 1200 Top Cover	1	44	SP01108	Hex Bolt M16 x 90	4
8	401529	Multislit 1200 Front Cover	1	45	SP02008	Nut M10 Nyloc (T)	28
9	401663	Tray Ballast (Optional)	2	46	SP02010	Nut M12 Nyloc (T)	2
10	D1044	Split Pin 1/8" x 1 1/4"	2	47	SP02028	Nut M16 Nyloc (T)	4
11	D1871	Rivet 3.2 x 6	2	48	SP03011	Washer M10 Form A	46
12	D6725	Washer Guard	9	49	SP14011	Insert 50mm Sq. 1.0-3.0	4
13	D6951	Tine	1	50	SP18015	Decal Multislit 1200	1
14	D6998	Tine	1				
15	D7226	Roller	2				
16	D7493	Tine	1				
17	D8326	Pin Linch 7/16"	3				
18	D8617	Top Link Pin 3/4"	1				
19	E1-1061	M6 Spring Washer	8				
20	E1-1063	M10 Spring Washer	4				
21	E1-1080	Washer M16 Form A	24				
22	E1-1132	Hex Bolt M10 x 70	8				
23	E1-1134	Hex Set Screw M10 x 80	22				
24	F20323	Insert 50mm Sq. 3.0-5.0	2				
25	F20327	Implement Mounting Pin	2				
26	F20606	Oilite Bush 16 x 20 x 20	16				
27	F20692	Extension Spring ETS 616	2				
28	F20723	Drop Leg Assembly 20	3				
29	F22430	Asahi BP207 35ID Pillow Block	2				
30	F32457	Roller Shaft	2				
31	F32458	Roller Frame	2				
32	F32459	Top Link Arm	4				
33	F32460	Bottom Ling Arm	4				
34	F32461	Pivot Pin	8				
35	F32462	Pivot Bracket	2				
36	F32463	Roller Pivot Bracket	2				
37	F32464	Scraper Blade	2				

sisis®

SISIS, Ashbourne Road, Kirk Langley, Derbyshire, DE6 4NJ, England.

Tel: +44 (0) 1332 824 777 | Fax: +44 (0) 1332 824 525 | Email: info@sisis.com | www.sisis.com

A division of Howardson Ltd. - a proudly British company
Company reg no 641526 - Vat No GB 345 9918 12