

sisis[®]

AUTOSLIT

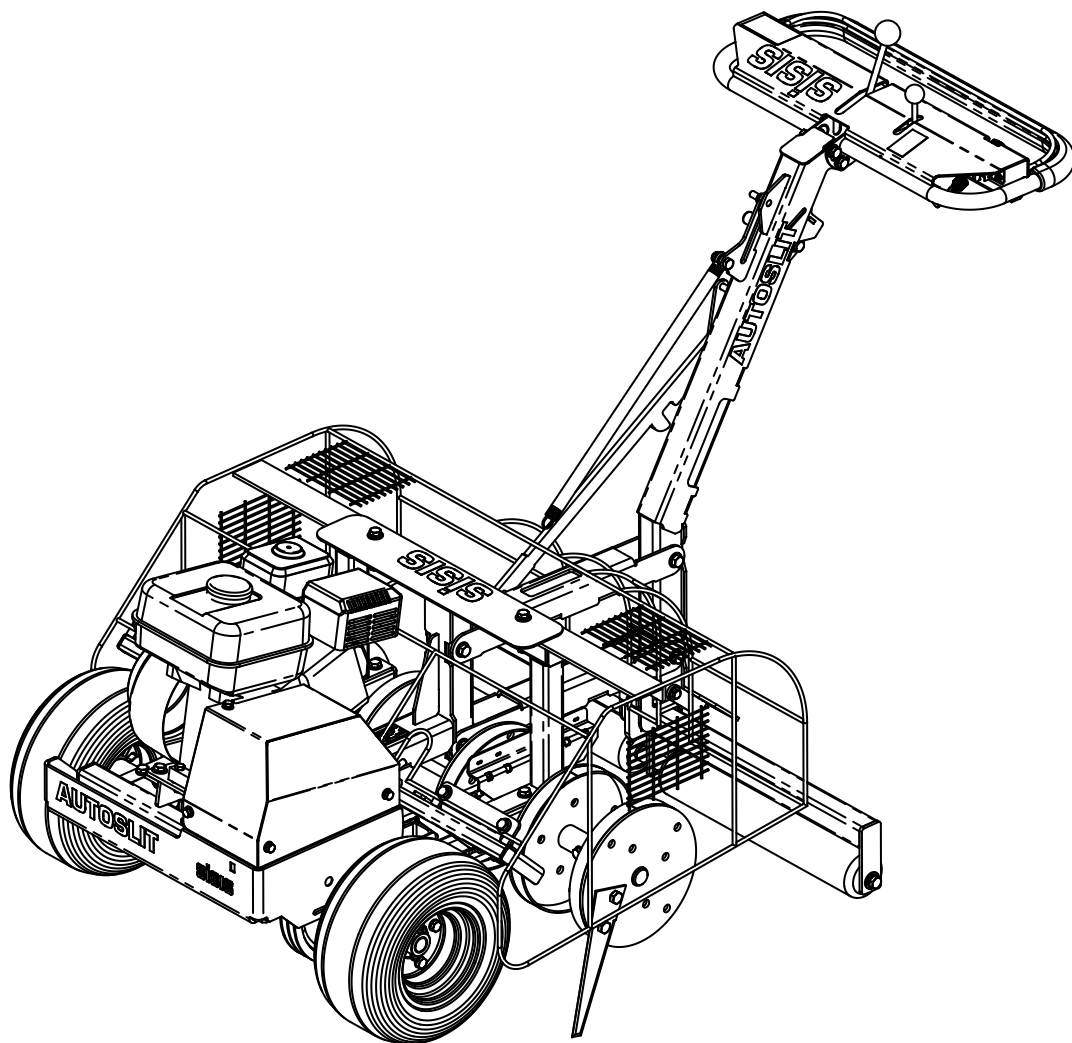

SISIS, Ashbourne Road, Kirk Langley, Derbyshire, DE6 4NJ, England.

Tel: +44 (0) 1332 824 777 | Fax: +44 (0) 1332 824 525 | Email: info@sisis.com | www.sisis.com

A division of Howardson Ltd. - a proudly British company
Company reg no 641526 - Vat No GB 345 9918 12

SP20018_REV_0
02/13

Certificate of Conformity

AUTOSLIT pedestrian slit aerator powered by Honda GX Petrol Engine

Manufacturer:- Howardson Ltd, Howardson Works, Kirk Langley, Derby, DE6 4NJ. UK

Owner of Technical Document:- Mr I.D. Howard, Howardson Ltd, Howardson Works Kirk Langley, Derby, DE6 4NJ, UK

Notified Body:- AV Technology Ltd, AVTECH house, Arkle Avenue, Stanley Green Trading Estate, Handforth, Cheshire, SK9 3RW, UK

I the under signed Declare that these machines:-

Tested at:- Howardson Works test site September 2011

Complies with the applicable requirements of:-

- Machine Directive 2006/42/EC
- Noise Directive 2000/14/EC (Annex VI Procedure 1)

Managing Director



Ian Howard

Serial Numbers



NOTE

MAKE A NOTE OF THE SERIAL NUMBERS OF YOUR MACHINE & ENGINE AND ALWAYS QUOTE THEM IN ANY COMMUNICATION WITH PERSONNEL AT DENNIS.

MACHINE SERIAL NUMBER

ENGINE SERIAL NUMBER

Introduction

The reliability and quality of performance of the **AUTOSLIT** depends upon some simple care maintenance carried out regularly. This manual has been prepared to allow the user to carry out all such work.

It is advisable to read the instructions carefully. Proper care and attention will enable the machine to give a continuous, satisfactory, and reliable service. Failure to carry out regular lubrication and maintenance as outlined in this manual may render any guarantee or warranty invalid.

In the case of any difficulty, or if further information or advice is required, our Service Department is always at your call. In the interests of speed and accuracy of information please quote the serial numbers of the machine and engine when making enquiries.

For the **AUTOSLIT**, this is to be found on a plate attached to the main frame. The engine number is stamped on either the crank case or the gear casing facing towards the front of the machine. We suggest you write the numbers on the front page of this book.

	Page
Certificate of Conformity	2
Serial Numbers	2
Introduction	2
Technical Data	3
Machine Description	4
Important Safety Instructions	5
Operating Instructions	6 - 7
Parts Listings	8 - 13

Technical Data

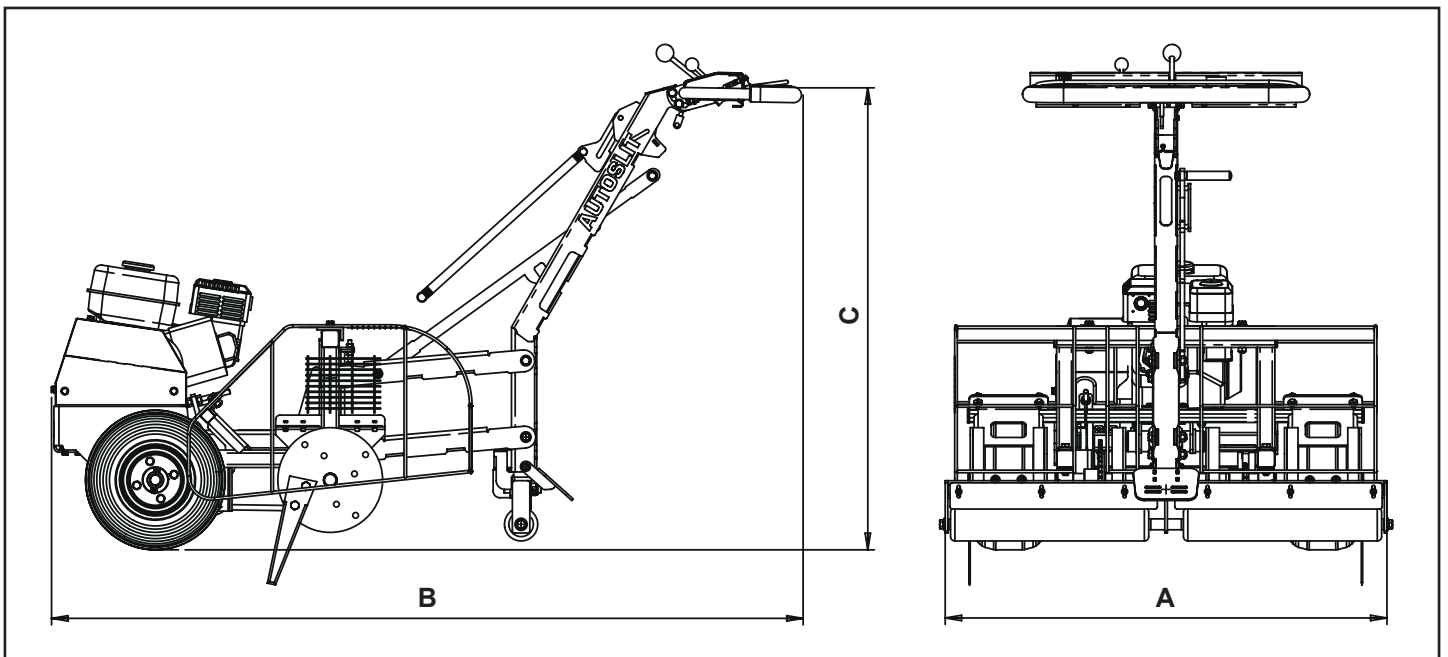

Model	AUTOSLIT
A - Width (M)	1.0
B - Length (M)	1.7
C - Height (M)	1.05
Weight (Kg)	160
Engine	Honda GX160 HXA
Wheels	13 x 6.5 -6 Slick
Number of Tines	30
Part Number - 152 x 3 thick	D6951
Part Number - 152 x 5 thick	D7493
Drive System	Belt Driven
Measured Sound Power Level dB(A) LWA	91
Guaranteed Sound Power Level dB(A) LWA	94

Machine Description

The **SISIS AUTOSLIT** is a pedestrian engine driven slit aerator, designed for the aeration of fine and outfield turf areas such as cricket, football, rugby, tennis, bowls and golf greens. The driven tine shaft fitted with selectable tines, aerates the surface in a smooth helix pattern. The tines are fitted to the driven tine plates and are configured to a patented design which allows the tines to enter and exit the ground with maximum subsurface disturbance and minimum surface disturbance.

A full width roller follows the tines to support the machine and reconstitute the surface with a pleasing striped finish. The depth of the tines is controlled by the cantilevered handle which is designed to raise the tines out of the ground requiring little operator effort. The front wheels are pneumatic slick tyres to reduce any surface marking.

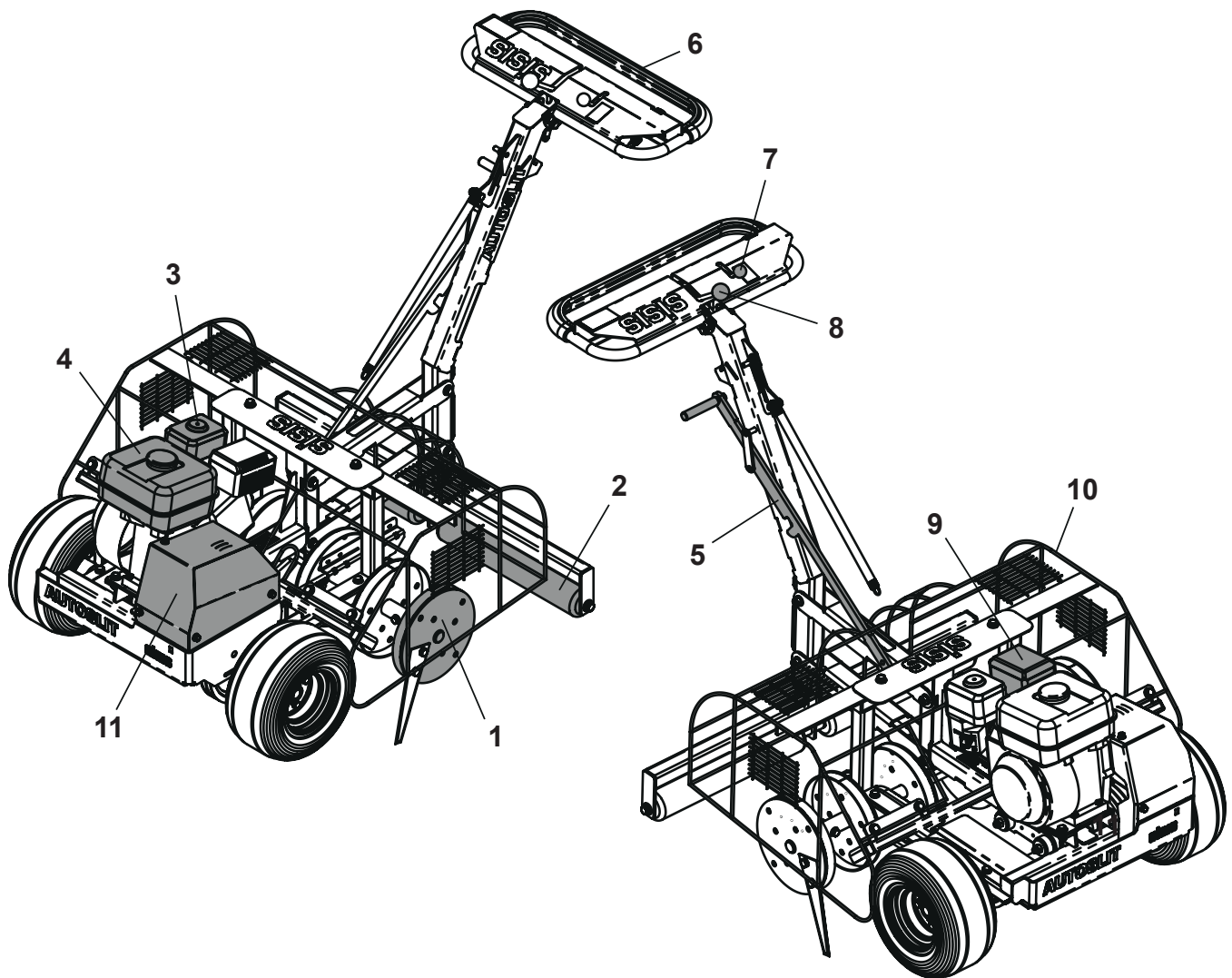

1. Tine Shaft
2. Rear Roller
3. Air Filter
4. Fuel Tank
5. Height Lever
6. Deadmans Handle

7. Throttle Lever
8. Drive Engage
9. Exhaust
10. Guard
11. Belt Guard

Important Safety Instructions

In order to operate the machine safely please follow these Health and Safety guidelines.

TRAINING



CAUTION

*READ THE INSTRUCTIONS CONTAINED IN THIS MANUAL WITH CARE. IF YOU ARE IN ANY DOUBT PLEASE ASK YOUR EMPLOYER OR CONTACT US DIRECT AT **SISIS**.*

- Be familiar with the controls and the proper use of the equipment.
- Never allow children or people unfamiliar with these instructions to use the **AUTOSLIT**. Local regulations or insurance may restrict the age of the operator.
- Keep in mind that the operator or user is responsible for accidents or hazards occurring to other people or their property.

PREPARATION



WARNING *PETROL IS HIGHLY FLAMMABLE AND WILL DAMAGE GRASS IF SPILT.*

- A) Store fuel in containers specifically designed for this purpose.
 - B) Refuel out doors and do not refuel whilst smoking.
 - C) Add fuel before starting the engine. Never remove the cap of the fuel tank or add petrol while the engine is running or when the engine is hot.
 - D) If petrol is spilled do not attempt to start the engine but move the machine away from the area of spill and avoid creating any sources of ignition until the vapours have dissipated.
- Replace damaged or faulty silencers.
 - Before using the machine always inspect the safety devices including the cut off switch and the blades for excessive wear or damage. Replace if necessary.

OPERATION

- Do not operate the engine in a confined space where dangerous **CARBON MONOXIDE** fumes can collect.
- Use extreme caution when reversing or pulling the machine towards you.



CAUTION

BEFORE YOU OPERATE THIS MACHINE YOU MUST READ AND STUDY THIS MANUAL. IF YOU ARE IN ANY DOUBT PLEASE ASK YOUR EMPLOYER OR CONTACT US DIRECT.

OPERATING INSTRUCTIONS

The **SISIS AUTOSLIT** is delivered with a kit of tines and fasteners loose, for safety of transport. For fitting of the tines ensure they are orientated correctly to the direction of travel (**See Figure 1**). The 90 degree edge of the tine is located to face the outside. The bolts are fitted through and secured with the nut on the inside of the bobbin. Always use **SISIS** tines as these have been developed to a specification of hardness and bend tolerance for optimum wear giving abrasion resistance and long life.

Before starting operation of the **AUTOSLIT** raise the machine onto a suitable surface to bring the engine level, check the oil level. Check all guards are securely fitted, and there are no loose fittings, worn or bent tines. The **AUTOSLIT** is fitted with safety switches and a 'Deadmans Handle' to ensure safe operation of the machine. To start the engine ensure that the drive engage/disengage lever is forward into the disengage drive position (**See Figure 2**).

To start the engine from cold pull the throttle lever back to the choke position, using the recoil start the engine, adjust the throttle to tick over and allow to warm. To operate the **AUTOSLIT** hold and press down the 'Deadmans Handle', pull back the throttle lever to a mid position, increasing the engine's revs, and slowly pull back the drive engage lever to the engage position (**See Figure 3**). Releasing the 'Deadmans Handle' cuts out the engine at any time.

The **AUTOSLIT** will now move forward as the wheels are driven from the V belt from the engine. Maneuvre the **AUTOSLIT** at the start of the first run. To lower the tines into the ground the 'Height Lever' requires lifting out of its catch position, (**See Figure 4**). The catch position is set to allow transport of the **AUTOSLIT** with the tines clear of the ground.

As the tines enter the turf to their full depth the 'Height Lever' adjusts its position. At the end of a run push forward the drive engage/disengage lever, this stops drive to the tine shaft. Push up on the Height Lever and the tines will exit the ground, stopping as the Height Lever finds the catch position.

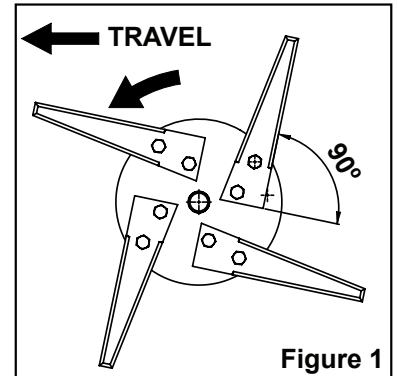

Figure 1

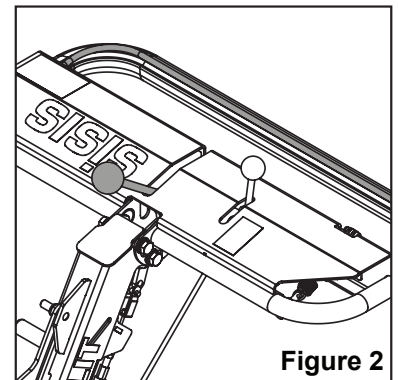

Figure 2

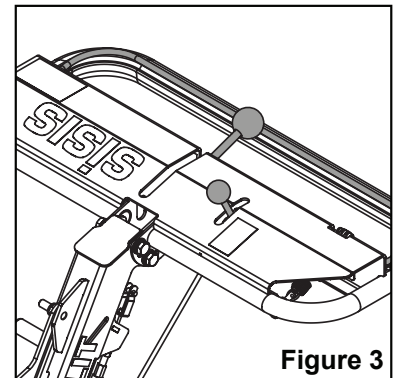

Figure 3

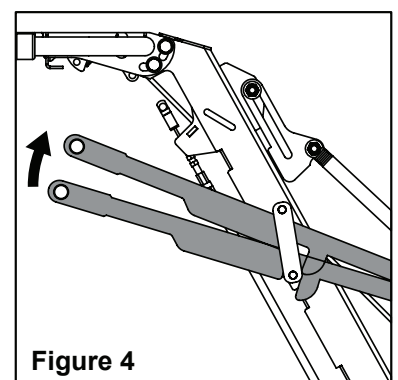

Figure 4

OPERATING INSTRUCTIONS

To aid manoeuvre of the **AUTOSLIT** to the next run kick up the Rear Roller lock, this allows the rear roller to pivot. To lock again simply kick back down when the Rear Roller is straight (**See Figure 5**). Always slit in straight lines for best performance of the tines.

TINE DEPTH ADJUSTMENT

The slitting depth of the tines can be adjusted if required. Turn off the engine, and safely remove the tine wire mesh guard. Loosen and adjust the two depth screws as shown, once set secure with the lock nuts (**See Figure 6**). Replace and secure the tine wire mesh guard.

MAINTENANCE

Engine - Honda GX160 HX4

Engine Oil - SAE 10w-40

Gearbox - SEA 10w-40

Tyre Pressures - 26 PSI

- Check tyre pressures
- Check engine oil level
- Check reduction gearbox oil
- Check all parts are secure, all fasteners are tight
- Check tines for damage and wear
- Grease all bearing and wheel hubs grease nipples
- Lightly oil cables and pivots
- Wipe tines with oil before storage

Check the belt tension. If the belt tension is insufficient to provide drive to the wheel axle pulley, remove the belt guard to gain access to tensioner and belt finger arrangement (**See Figure 7 & 8**). Release the belt tensioner by pushing the Drive Engage. Lever forward. Loosen the engine bolts and slide the engine forward so that any belt slack is removed, increase the tension but still allowing the engine pulley to turn without driving the belt.

Apply the belt tensioner by pulling the Drive Engage Lever rearward. Now adjust the belt finger so that it is 2mm clear of the belt, secure with the 2 lock nuts. Further adjustment of the belt tensioner can be done by adjusting the cable adjusting nuts at the handle (**See Figure 9**).

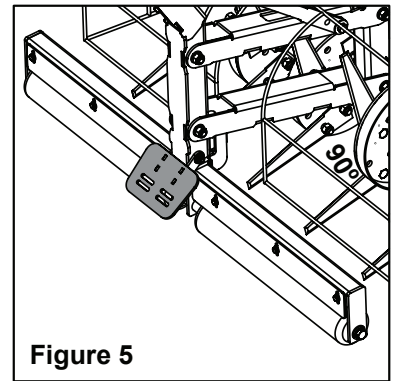

Figure 5

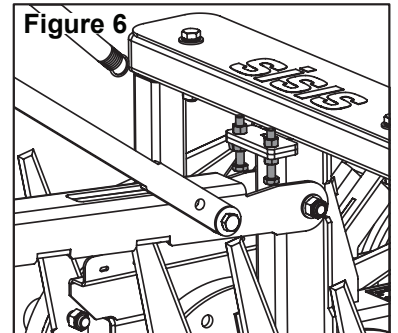

Figure 6

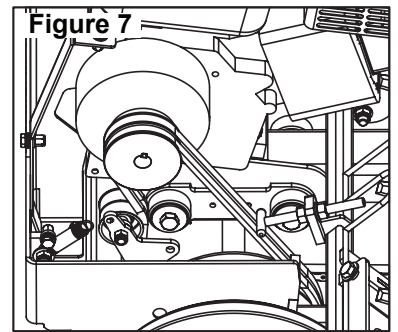

Figure 7

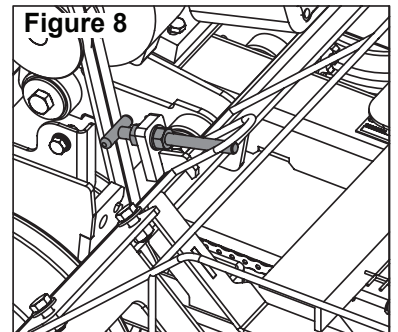

Figure 8

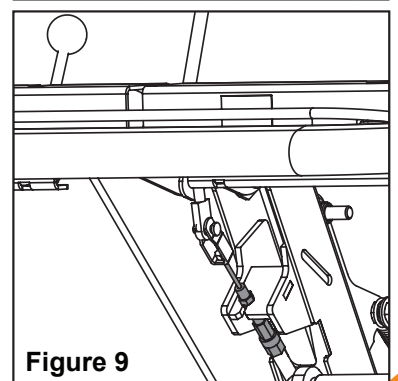
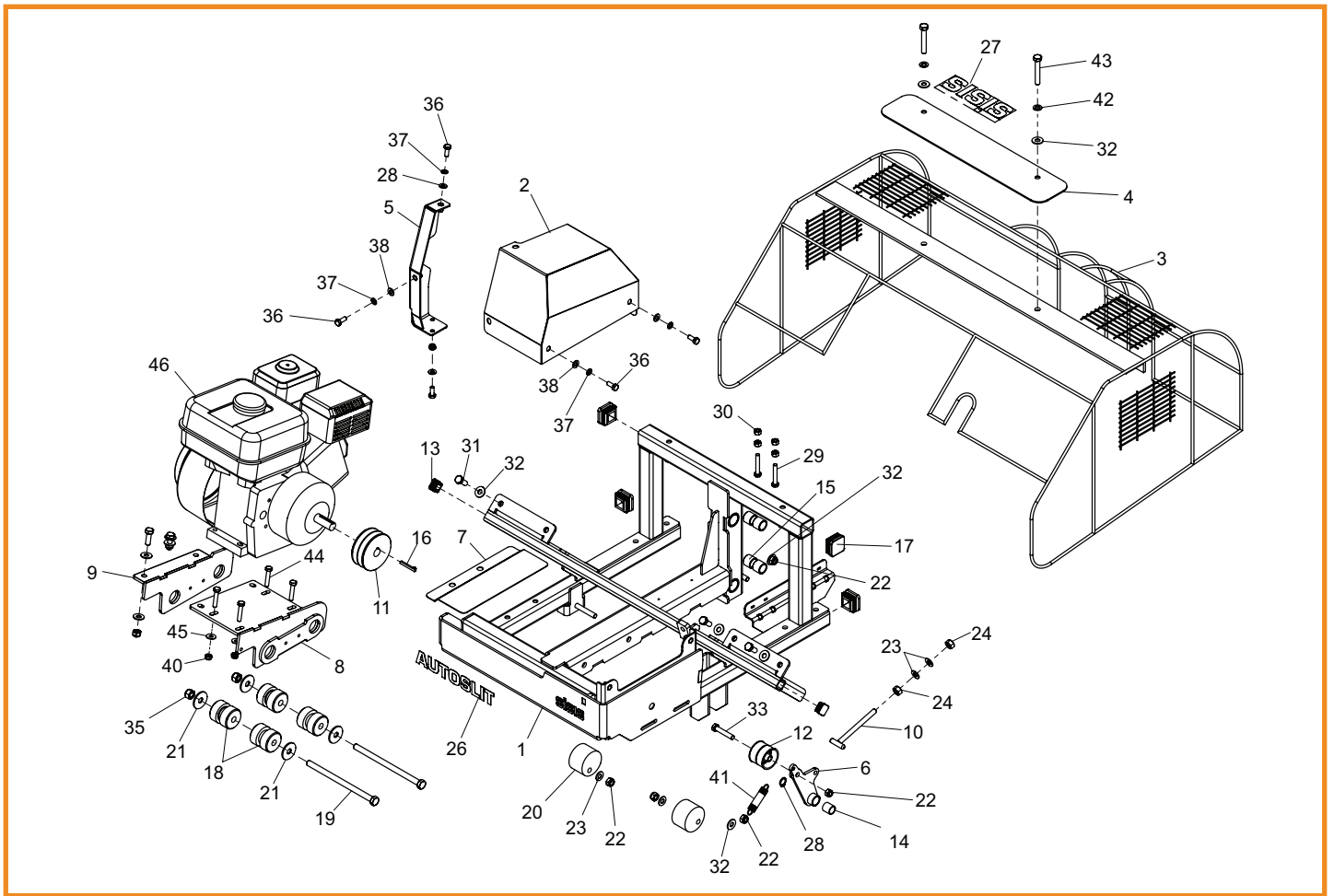

Figure 9



1.01

Main Chassis

Item No.	Part No.	Description	Quantity	Item No.	Part No.	Description	Quantity
1	F36185	Frame Assembly	1	39	SP01105	Hex Set Screw M10 X 30	2
2	401746	Belt Guard WA	1	40	SP02006	Nut M8 Nyloc (T)	6
3	F36153	Wire Guard Autoslit	1	41	F20141	Tension Spring 16mm OD x 76mm Long x 1.6mm"	1
4	F36202	Transfer Plate	1	42	Sp03034	Washer M10 Spring Lock	2
5	401742	Guard Engine Side	1	43	E1-1130	Hex Bolt M10 x 65	2
6	401734	Lever Belt Tensioner WA	1	44	SP01027	Hex Set Screw M8 x 40	4
7	F36199	Chain Cover	1	45	SP03015	Washer M8 Form C	4
8	F35603	Engine Mtd Bracket	1	46	F21734	Engine Honda GX160 HX4-OH	1
9	F35605	Bracket Lock Plate	1				
10	F36252	Belt Stay	1				
11	F35197	Engine Pulley 80PCD 2A	1				
12	D8435	Pulley	1				
13	F21367	Tube Bung 25 x 25	2				
14	F20606	Oilite Bush 16 x 20 x 20	1				
15	D8381	Oilite Bush 20 x 25 x 20	4				
16	D1005	Key Gib 3/16" x 3/16" x 1 3/4"	1				
17	D8955	Tube Bung 40 x 40	5				
18	F20008	Vib Mount GB22002-11	4				
19	F21594	Hex Set Screw M12 x 200	2				
20	F34649	Tensioner Block	2				
21	F35628	Bracket Washer	4				
22	SP02008	Nut M10 Nyloc (T)	6				
23	SP03011	Washer M10 Form A	4				
24	SP02007	Nut M10 STD	2				
25	SP02044	Rivnut Hex M8 (0.5-3.0) [No Head]	4				
26	SP18014	Decal Autoslit	1				
27	F35013	Decal Sisis Black 50mm Height	1				
28	D8188	Circlip D1400-16	1				
29	SP01022	Hex Set Screw M8 x 50	2				
30	SP02005	Nut M8 Std	4				
31	SP01035	Hex Set Screw M10 x 25	4				
32	SP03016	Washer M10 Form C	12				
33	SP01013	Hex Set Screw 3/8" UNF x 2"	1				
34	SP02018	Nut 3/8" UNF Nyloc (T)	1				
35	SP02010	Nut M12 Nyloc (T)	2				
36	SP01009	Hex Set Screw M8 X 20	6				
37	SP03029	Washer M8 Spring Lock	4				
38	SP03008	Washer M8 Form A	6				

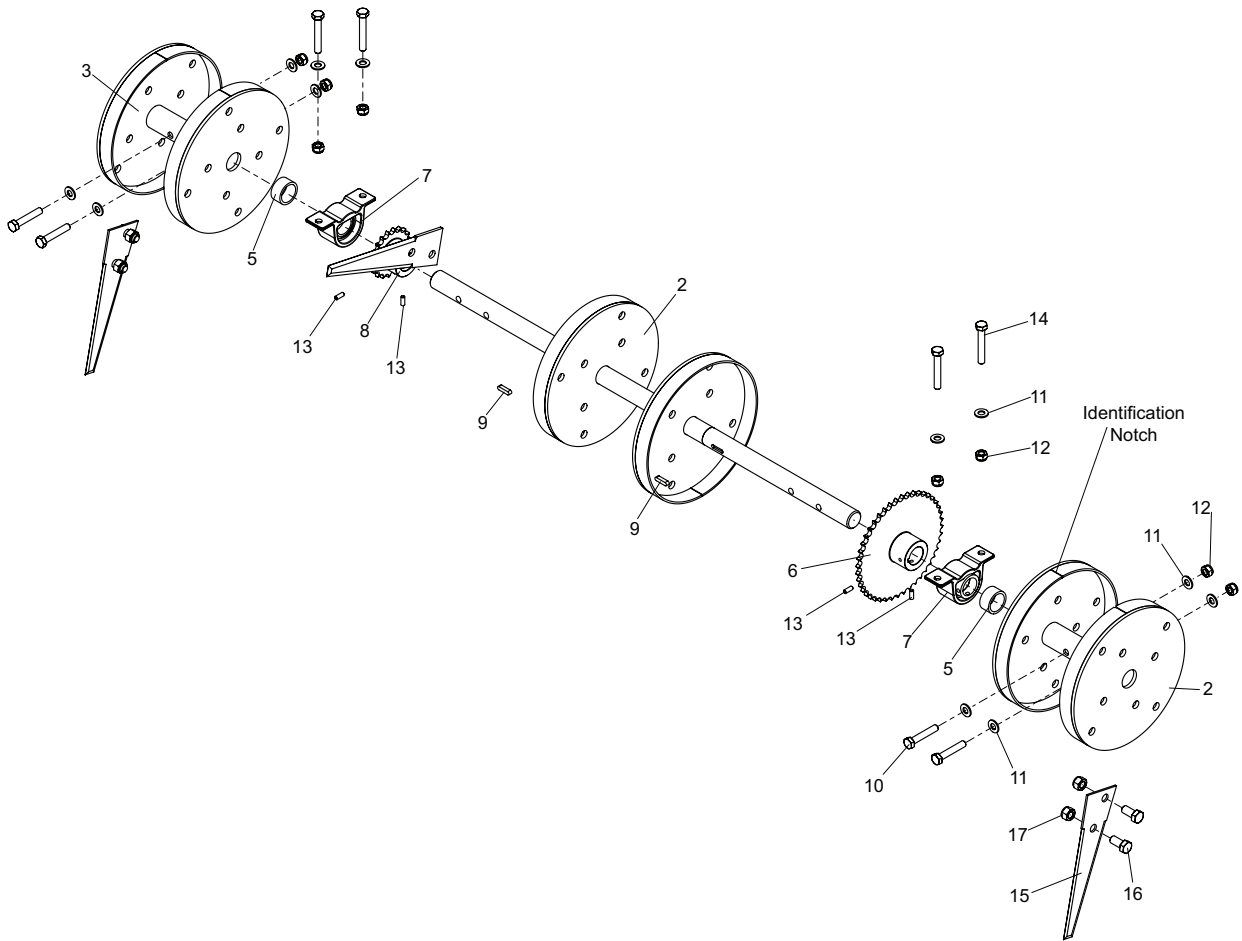

2.01

Tine Shaft Assembly

Item No.	Part No.	Description	Quantity
1	F35182	Tine Shaft	1
2	401720	Tine Shaft Extension LH	1
3	401721	Tine Shaft Extension RH	1
4	F35546	Chain Pinion	1
5	F21596	Bearing PB Asahi BPP 6.Z	2
6	F35547	Chain Pinion	1
7	F35549	Sleeve 30 x 38 x 19	2
8	D6951	Tine	24
9	D8165	Key Parallel 6 x 6 x 25	2
10	D8229	Hex Set Screw M10 x 55	4
11	Sp03011	Washer M10 Form A	12
12	Sp02008	Nut M10 Nyloc (T)	8
13	D8036	Grub Screw M6 x 16	4
14	SP01059	Hex Set Screw M12 x 25	48
15	SP02010	Nut M12 Nyloc (T)	48
16	E1-1130	Hex Bolt M10 x 65	4
17	D7493	Tine	1

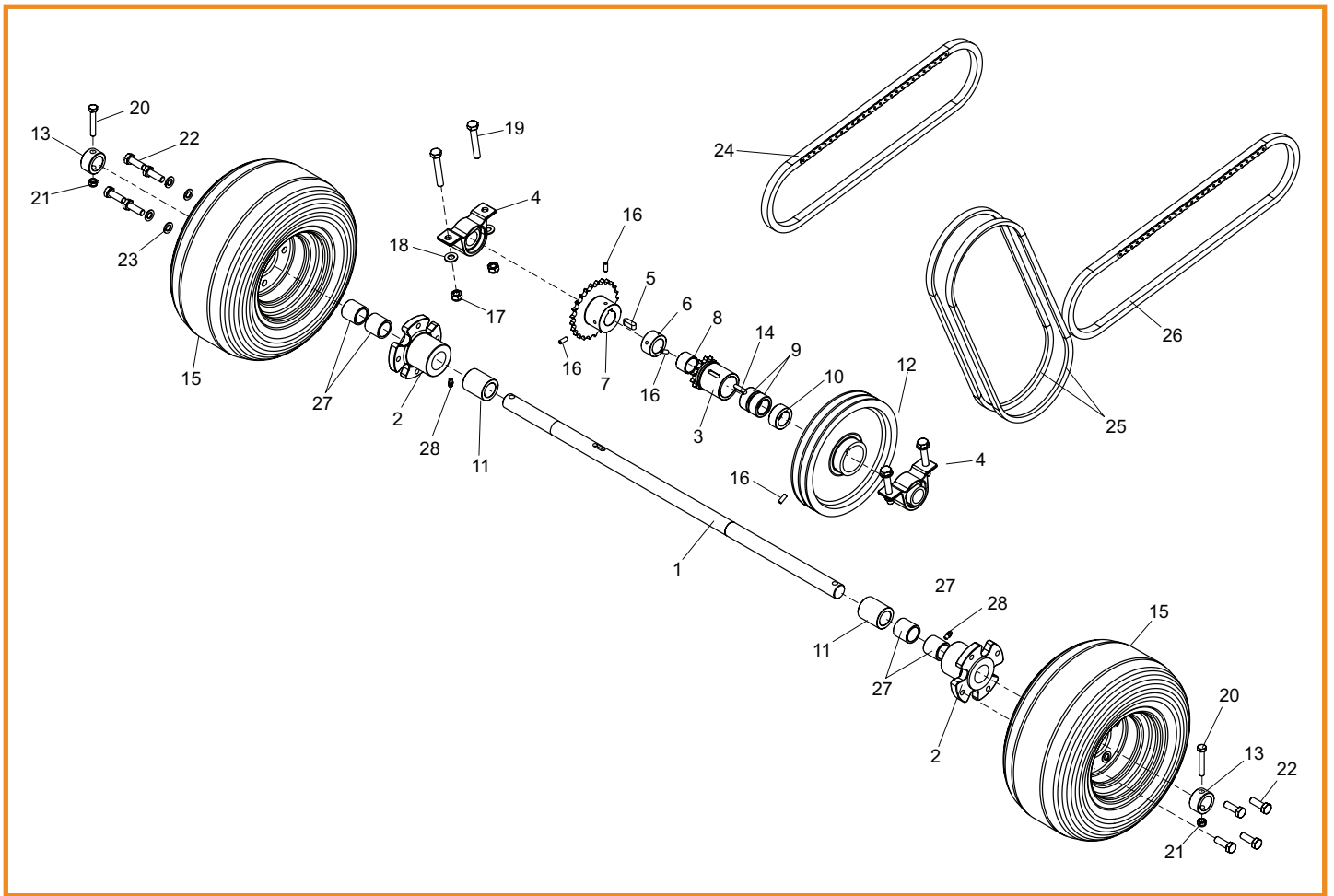

3.01

Wheel Axle Assembly

Item No.	Part No.	Description	Quantity
1	F35195	Drive Shaft	1
2	F35191	Wheel Hub	2
3	F35536	Pulley Sleeve	1
4	F21582	Bearing PB Asahi BPP 5.Z	2
5	D1934	Key Parallel 8 x 8 x 25	1
6	F35542	Locking Sleeve 20 x 25 x 40	1
7	F35548	Chain Pinion	1
8	D8129	Oilite Bush 25 x 30 x 20	1
9	F21583	Needle Roller Bearing RNA4904	2
10	F35543	Spacer 16 x 25 x 40	1
11	F35193	Spacer 44 x 25 x 40	2
12	F35537	Vee Belt Pulley 8" PCD 2A	1
13	F35194	Locking Collar 20 x 25 x 40	2
14	D8165	Key Parallel 6 x 6 x 25	1
15	F21061	Wheel	2
16	D8036	Grub Screw M6 x 16	4
17	SP02008	Nut M10 Nyloc (T)	4
18	SP03011	Washer M10 Form A	4
19	E1-1130	Hex Bolt M10 x 65	4
20	SP01022	Hex Set Screw M8 x 50	2
21	SP02006	Nut M8 Nyloc (T)	2
22	SP01105	Hex Set Screw M10 x 30	8
23	SP03034	Washer M10 Spring Lock	8
24	D2988	Roller Chain 87P x 1/2"	1
25	D2934	Belt 'V' A 40 A1050	2
26	D1721	Roller Chain 93P x 1/2"	1
27	F21581	Roller Clutch Torrington FCB25	4
28	D1947	Grease Nipple M6	2

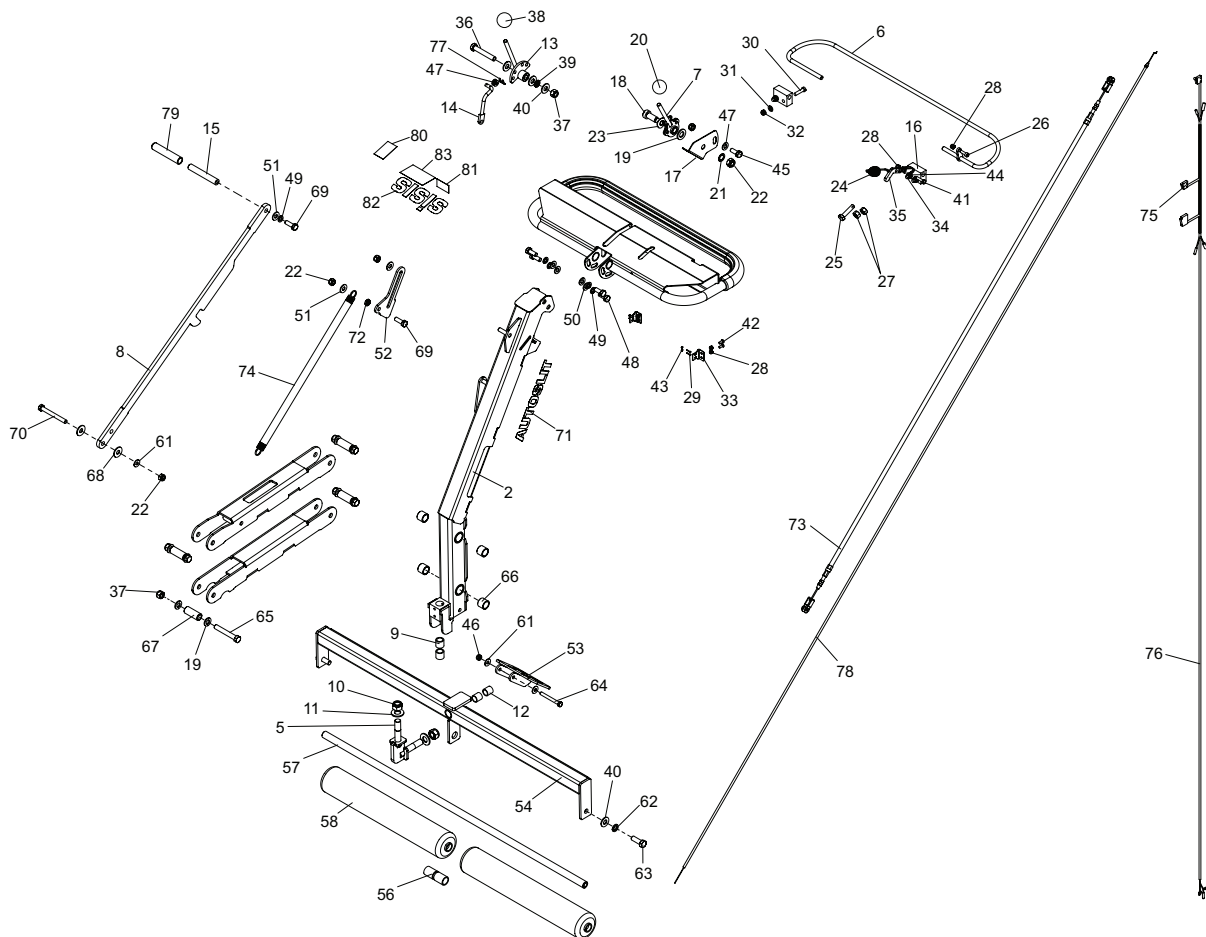

4.01

Handle Assembly

Item No.	Part No.	Description	Quantity	Item No.	Part No.	Description	Quantity
1	401766	Autoslit Handle Moulding Assy	1	43	SP02032	Nut M2 STD	4
2	401759	Handle Channel WA	1	44	SP03009	Washer M5 Form A	1
3	401735	Lower Parallel WA	1	45	SP01009	Hex Set Screw M8 x 20	1
4	401738	Upper Parallel WA	1	46	SP02006	Nut M8 Nyloc (T)	2
5	401718	Ra Pivot WA	1	47	SP03008	Washer M8 Form A	3
6	230180	Safety Bar W.A.	1	48	SP01035	Hex Set Screw M10 x 25	4
7	230190	Throttle Lever W.A.	1	49	E1-1063	M10 Spring Washer	5
8	401763	Plate Latch Thick	1	50	SP03011	Washer M10 Form A	4
9	D8158	Oilite Bush 16 x 22 x 20	2	51	SP03016	Washer M10 Form C	3
10	SP02028	Nut M16 Nyloc (T)	2	52	401773	Link Sliding Handle	1
11	SP03021	Washer M16 Form C	2	53	F35506	Roller Lock	1
12	F20606	Oilite Bush 16 x 20 x 20	2	54	F35199	Roller Frame	1
13	290058	Control Lever Assy	1	55	F35200	Roller Spacer Frame	2
14	F36200	Over Centre Rod	1	56	F35617	Roller Spacer	2
15	401765	Handle Lock Lever	1	57	F35616	Roller Shaft	1
16	229585	Pivot Block	2	58	D2994	Roller	2
17	230196	Throttle Plate	1	59	SP03014	Washer M6 Form C	6
18	SP01029	Shoulder Bolt 12 x 25 M10	1	60	SP01008	Hex Set Screw M6 x 16	6
19	SP03012	Washer M12 Form A	9	61	SP03015	Washer M8 Form C	3
20	SP03019	Washer M12 Wave	1	62	E1-1065	Spring Washer M12 Sq Section	2
21	SP03020	Shim 12 x 18 x 1	2	63	SP01111	Hex Set Screw M12 x 35	2
22	SP02008	Nut M10 Nyloc (T)	4	64	E1-1116	Hex Set Screw M8 x 70	1
23	J20017	Knob - Red	1	65	E1-1167	Hex Bolt M12 x 80	4
24	229167	Clutch Spring	1	66	D8381	Oilite Bush 20 x 25 x 20	4
25	229620	Bolt For Spring	1	67	F35204	Pivot Pin	4
26	SP01043	Cap Head M5 x 16	1	68	SP03018	Washer M10 Form G	2
27	SP02005	Nut M8 STD	2	69	SP01105	Hex Set Screw M10 x 30	2
28	SP02002	Nut M5 Nyloc (T)	6	70	E1-1136	Hex Bolt M10 x 90	1
29	SP01070	Cap Head M2 x 12	4	71	SP18014	Decal Autoslit	1
30	SP01101	Screw M6 x 25 Slotted	4	72	SP02013	Nut M10 Lock (Thin)	1
31	SP03010	Washer M6 Form A	4	73	F35376	Control Cable	1
32	SP02004	Nut M6 Nyloc	4	74	F21836	Tension Spring	1
33	240169	Sensor Angle Plate	2	75	SP12049	Handle Controls Cable	1
34	401784	Link Safety Bar	2	76	SP12048	Harness Engine Autoslit	1
35	401790	Link Safety Switch	1	77	D1040	Split Pin 3/32" x 3/4"	2
36	E1-1166	Hex Bolt M12 x 75	1	78	SP12047	Throttle Cable Autoslit	1
37	SP02010	Nut M12 Nyloc (T)	5	79	F21806	Handle Grip 16ID x 100Lg	1
38	176457	Black Knob M10	1	80	SP18001	Decal Throttle (Razor)	1
39	D1887	Thackery Washer M12	1	81	229599	Engine On / Off Decal	1
40	SP03017	Washer M12 Form C	5	82	F35013	Decal Sisis Block 50mm Height	1
41	SP01004	Hex Set Screw M5 x 20	1	83	B32903	Union Jack Decal	1
42	SP01069	Button Head M5 x 12	4				

sisis®

SISIS, Ashbourne Road, Kirk Langley, Derbyshire, DE6 4NJ, England.

Tel: +44 (0) 1332 824 777 | Fax: +44 (0) 1332 824 525 | Email: info@sisis.com | www.sisis.com

A division of Howardson Ltd. - a proudly British company
Company reg no 641526 - Vat No GB 345 9918 12