

# DENNIS

## FT & SUPER SIX

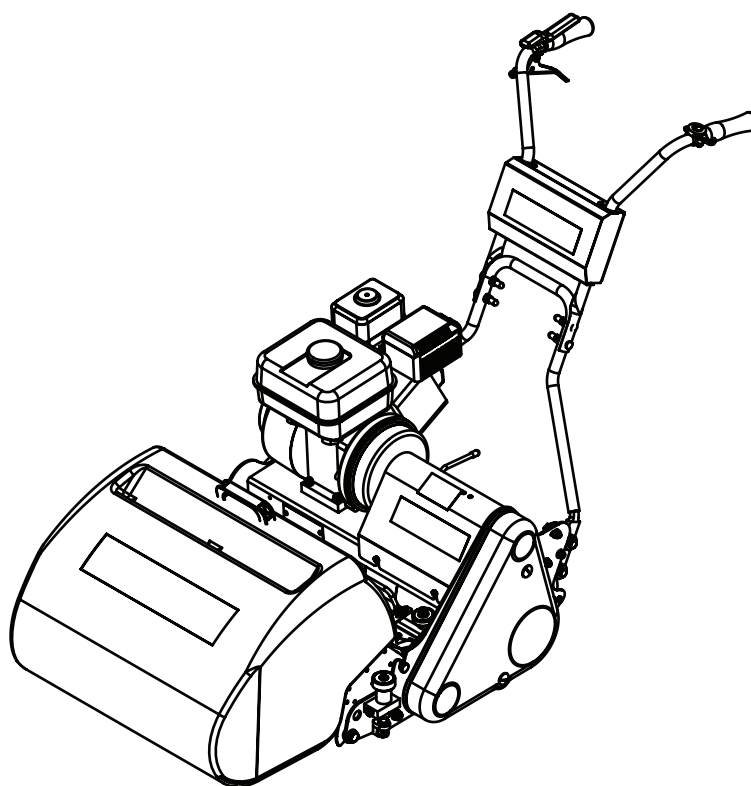

### FINE TURF CASSETTE MOWER INSTRUCTION MANUAL

DENNIS, Ashbourne Road, Kirk Langley, Derby, DE6 4NJ, United Kingdom

Telephone:- 01332 824777

Fax:- 01332 824 525











E-mail:- sales@dennisuk.com

E-mail:- spares@dennisuk.com

[www.dennisuk.com](http://www.dennisuk.com)

SP20001\_REV\_6  
05/13

# Product Application Matrix

Applications	FT Range	Razor Ultra	Razor	Simplex Range	G560 G680	SuperSix Range	G660 G760 G860	Premier Range	Verticut TT	S500 PLUS	Bray Hand Tools	Gang Mower
Bowls   	●	●	●			Croquet and Tennis only	Croquet and Tennis only	Tennis only	●	●	●	
Football   							●	●		●		●
Cricket 	●	●	●	●	●	●	●	●	●	●	●	●
Golf 	●	●	●	●	●	●	●	●	●	●	●	●
Ornamental/ Lawns 	●			●	●	●	●	●	●	●	●	●
Local Authority/ Contractors 	●	●	●	●	●	●	●	●	●	●	●	●



**NOTE**

THIS INFORMATION IS INTENDED FOR GUIDANCE PURPOSES ONLY. WE RECOMMEND THAT YOU DISCUSS YOUR SPECIFIC REQUIREMENT WITH OUR HEAD OFFICE, SALES MANAGERS OR YOUR LOCAL DENNIS DEALER.

# Certificate of Conformity

## Fine Turf (FT) Cylinder mowers powered by Honda GX Petrol Engine

**Manufacturer:-** Howardson Ltd, Howardson Works, Kirk Langley, Derby, DE6 4NJ. UK

**Owner of Technical Document:-** Mr I.D. Howard, Howardson Ltd, Howardson Works Kirk Langley, Derby, DE6 4NJ, UK

**Notified Body:-** AV Technology Ltd, AVTECH house, Arkle Avenue, Stanley Green Trading Estate, Handforth, Cheshire, SK9 3RW, UK

I the under signed Declare that these machines:-

Model	Cutting Width	Power (Honda)	Measured Sound Power Level	Guaranteed Sound Power Level	Serial Number
FT 430	17" (430mm)	GX120	91dB Lwa	94dB Lwa	See Product ID range
FT 510	20" (510mm)	GX160	95dB Lwa	98dB Lwa	See Product ID range
FT 610	24" (610mm)	GX160	95dB Lwa	98dB Lwa	See Product ID range

**Tested at:-** Howardson Works test site September 2011

Complies with the applicable requirements of:-

- Machine Directive 2006/42/EC
- Noise Directive 2000/14/EC (Annex VI Procedure 1)

**Managing Director**



Ian Howard

## Serial Numbers



### **NOTE**

*MAKE A NOTE OF THE SERIAL NUMBERS OF YOUR MACHINE & ENGINE AND ALWAYS QUOTE THEM IN ANY COMMUNICATION WITH PERSONNEL AT DENNIS.*

### **MACHINE SERIAL NUMBER**

### **ENGINE SERIAL NUMBER**

## Introduction

The reliability and quality of performance of the **DENNIS FT** depends upon some simple care maintenance carried out regularly. This manual has been prepared to allow the user to carry out all such work.

It is advisable to read the instructions carefully. Proper care and attention will enable the machine to give a continuous, satisfactory, and reliable service. Failure to carry out regular lubrication and maintenance as outlined in this manual may render any guarantee or warranty invalid.

In the case of any difficulty, or if further information or advice is required, our Service Department is always at your call. In the interests of speed and accuracy of information please quote the serial numbers of the machine and engine when making enquiries.

For the mower, this is to be found on a plate attached to the side frame. The engine number is stamped on either the crank case or the gear casing facing towards the front of the machine. We suggest you write the numbers on the front page of this book.

	Page
Product Application Matrix.....	2
Declaration of Conformity.....	3
Serial Numbers.....	3
Introduction.....	3
Technical Data.....	4
Machine Description.....	5
Important Safety Instructions.....	6
Operating Instructions.....	7 - 8
General Adjustments.....	9 - 11
Removing The Cassette Unit.....	12
Routine Maintenance.....	13 - 14
General Lubrication.....	15 - 16
Storage.....	16
Guide to Replacement Parts.....	16
Guide To Cassette Use.....	17
Parts Listings.....	18 - 39

## Technical Data

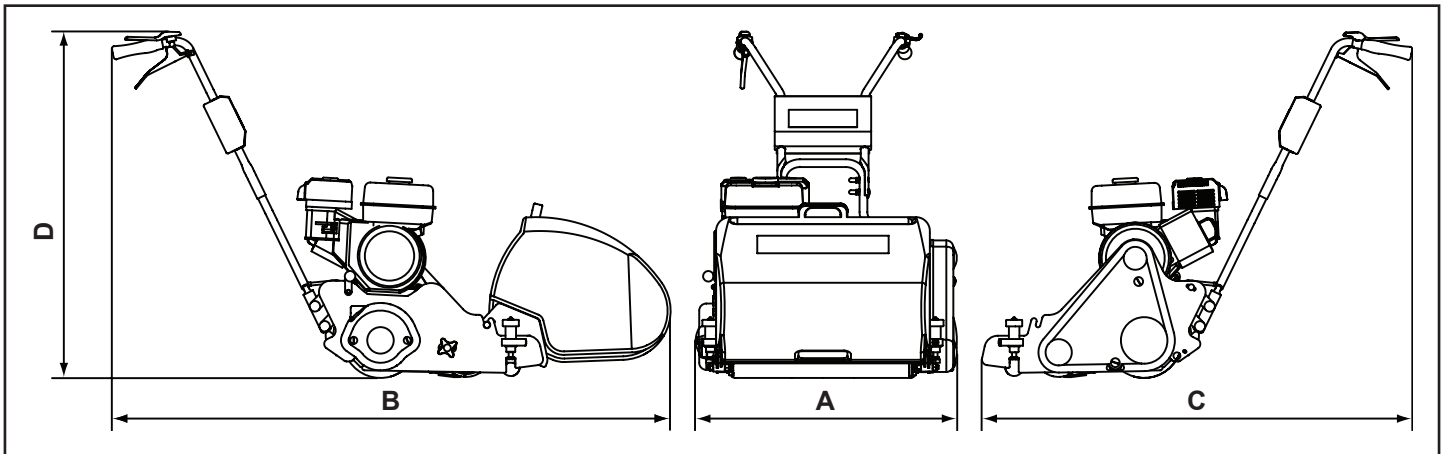

Model	FT430	FT510	FT610
A - Width (mm)	675	750	840
B - Length with Grassbox (mm)	1592	1592	1592
C - Length without Grassbox (mm)	1229	1229	1229
D - Height (mm)	971	971	971
Weight (Kg)	100	110	120
Cutting Width (mm)	430	510	610
Cylinder	9 or 5 blade		
Height of Cut (mm)	2 - 25		
Cut Performance (9 Blade)	180 cuts/m (168 cuts/yd)		
Engine	Honda GX120	Honda GX160	Honda GX160
Drive System	Brake band for roller and dog drive to disengage cutter for transport		
Final Drive	Poly "V" high performance belts under constant tension		
Hand Arm Vibration (m/sec <sup>2</sup> ) (EN836)	2.7	2.5	2.8
Measured Sound Power Level dB(A) LWA	91	95	95
Guaranteed Sound Power Level dB(A) LWA	94	98	98
Measured Sound Pressure Level dB LPA	77	81	81

**NOTE:-** Mandatory Ear Protection required when Sound Pressure Levels reach 85 dB LPA.

# Machine Description

Manufactured with a 17" (43cm) 20" (51cm) or 24" (61cm) cutting width this mower is powered by a 5.5 h.p. air cooled single cylinder four stroke petrol engine (3.5hp FT430) The rear roller is powered via a slipping brake band clutch mechanism that allows infinite speed control independent of the cutter unit. The drive to the roller is engaged by a lever situated on the right handlebar.

Where possible, steps have been taken during the design of this machinery to reduce noise emission\*\*\*.

To take full advantage of this, it is essential that the machine only be used when setup correctly and is fully serviceable (see instructions).

\*\*\* including fitment of low noise variant Honda engine.

In the design of the machine, special attention has been given to the importance of easy service and maintenance with the construction based on a sectional assembly system. These are the Engine Unit, the Cassette Unit, the Rear Roller Unit, and the Front Roller Unit, each of which can be readily removed individually from the main Frame Chassis Unit.

The interchangeable cassette system allows a variety of cassettes to be used for varying applications.

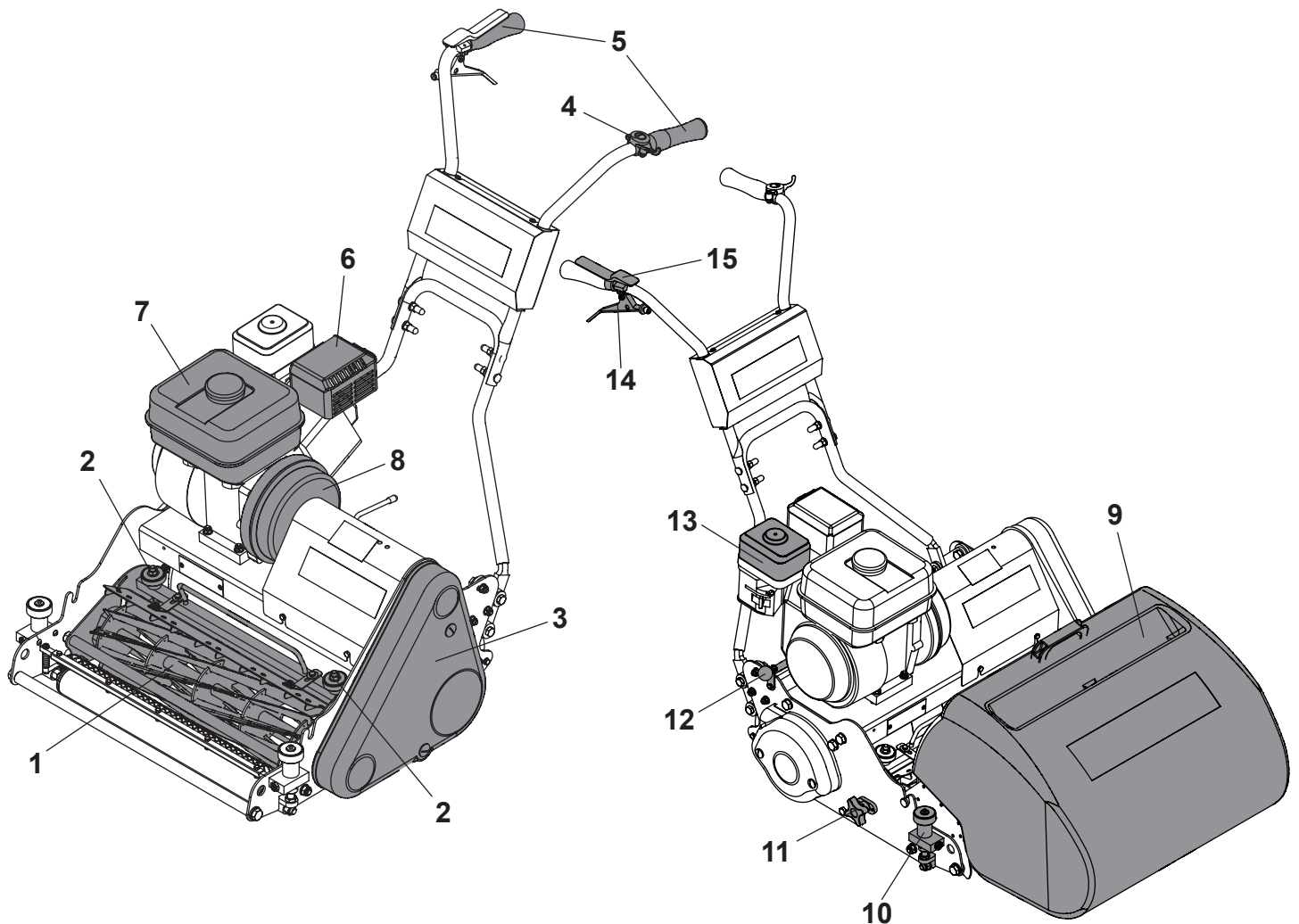

- |                               |  |
|-------------------------------|--|
| 1. Cassette                   | 9. Grassbox                                  |
| 2. Bottom Blade Adjuster Knob | 10. Cutting Height Adjustment Knob (FT Only) |
| 3. Belt Guard                 | 11. Cassette Retaining Pin Hand Wheel        |
| 4. Throttle Lever             | 12. Cassette Disengage Knob                  |
| 5. Operating Handle           | 13. Air Filter                               |
| 6. Exhaust                    | 14. Driving Clutch Lever                     |
| 7. Fuel Tank                  | 15. Deadmans Handle                          |
| 8. Centrifugal Clutch Drum    |  |

# Important Safety Instructions

In order to operate the machine safely please follow these Health and Safety guidelines.

## TRAINING



### **CAUTION**

*READ THE INSTRUCTIONS CONTAINED IN THIS MANUAL WITH CARE. IF YOU ARE IN ANY DOUBT PLEASE ASK YOUR EMPLOYER OR CONTACT US DIRECT AT **DENNIS**.*

- Be familiar with the controls and the proper use of the equipment.
- Never allow children or people unfamiliar with these instructions to use the mower. Local regulations or insurance may restrict the age of the operator.
- Never mow while people, especially children, or pets are nearby.
- Keep in mind that the operator or user is responsible for accidents or hazards occurring to other people or their property.

## PREPARATION

- While mowing always wear substantial footwear and long trousers. Do not operate the mower barefoot or in open sandals.
- Thoroughly inspect where the equipment is to be used and remove all stones, sticks, wire, bones and other foreign objects.



**WARNING** *PETROL IS HIGHLY FLAMMABLE AND WILL DAMAGE GRASS IF SPILT.*

- A) Store fuel in containers specifically designed for this purpose.
  - B) Refuel out doors and do not refuel whilst smoking.
  - C) Add fuel before starting the engine. Never remove the cap of the fuel tank or add petrol while the engine is running or when the engine is hot.
  - D) If petrol is spilled do not attempt to start the engine but move the machine away from the area of spill and avoid creating any sources of ignition until the vapours have dissipated.
- Replace damaged or faulty silencers.
  - Before using the machine always inspect the safety devices including the cut off switch and the blades for excessive wear or damage. Replace if necessary.

## OPERATION

- Do not operate the engine in a confined space where dangerous **CARBON MONOXIDE** fumes can collect.
- Mow only in daylight or good artificial light.
- Avoid operating the machine in wet grass where feasible.
- Always be sure of your footing on slopes.
- Walk. Never run.
- Walk across the face of slopes, never up and down.
- Exercise extreme care on slopes when changing direction.
- Do not mow excessively steep slopes.
- Use extreme caution when reversing or pulling the machine towards you.
- Stop the blades if the mower has to be tilted for transportation when crossing surfaces other than grass and when transporting the mower to and from the area to be mown.
- Never operate the mower with defective guards or shields or without the safety devices, for example without the deflector plate or grassbox in place.
- Do not change the engine governor settings or overspeed the engine.
- Disengage all blades and drive clutches before starting.
- Start the engine carefully following the instructions with feet well away from the blades.
- Do not tilt the mower when starting the engine.
- Do not put hands or feet near or under rotating parts. Keep clear of the discharge opening at all times.
- Never pick up or carry the mower while the engine is running.



## **CAUTION**

**BEFORE YOU OPERATE THIS MACHINE YOU MUST READ AND STUDY THIS MANUAL. IF YOU ARE IN ANY DOUBT PLEASE ASK YOUR EMPLOYER OR CONTACT US DIRECT.**

### **PREPARATION FOR USE**

- Before commencing ensure the turf is free from stones or other obstructions which may damage the cassette unit.
- Set the height of cut to the required level (see page 9)
- Check the engine.
- Fill the fuel tank 3/4 full with unleaded petrol.
- Always check the oil levels of the machine prior to commencing. Full details are given in the **ENGINE** Manual, which accompanies this book. A daily check is recommended. (Recommended grade oil is SAE 10W-40).
- Disengage the cassette unit. (see next page)
- Set the throttle control on the handle bars to the idle position.
- In the case of deadmans handle control depress the lever onto the handlebar then start the engine as per the manufacturers instructions.



## **CAUTION**

**IMPORTANT INFORMATION PLEASE READ ALL THE DETAILS IN THIS SECTION AND FAMILIARIZE YOURSELF AND ALL MACHINE OPERATORS WITH THE CONTENTS.**

### **GENERAL**

A centrifugal clutch is fitted in the primary drive system. When the engine revs are at tickover the clutch disengages and neither the cutter nor the rear roller controls will function. Under these conditions the Deadmans Control can be released and the engine will continue to tick over.

On increasing the revs of the engine with the throttle control the clutch engages thus allowing cutter and roller to operate.



## **NOTE**

**THE DEADMANS LEVER MUST BE DEPRESSED WHEN INCREASING THE ENGINE REVS OR THE MACHINE WILL STOP**

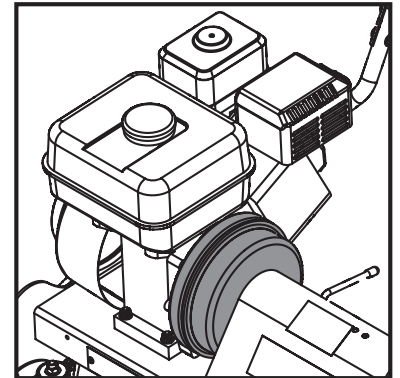

The drive to the cutter unit can be engaged or disengaged in one of two ways:-

- A) By reducing the engine revs to tickover the centrifugal clutch will disengage. This method will be performed when emptying the grassbox.
- b) By having the dog drive disengaged. Use this method when transporting the machine.

When the centrifugal clutch is engaged the rear roller drive can be activated by the brake band lever.

### **TRANSPORT (Disengaging the Cassette Drive)**

To ensure the safety of operator and machine we strongly recommend disengaging the cassette drive when transporting under power between sites. Do not operate any cassettes with dog drive disengaged except for the sorrel roller, ironing roller and slitter. This is achieved by performing the following procedure:

- 1) Reduce engine revs to tickover. This will cause the black clutch drum to cease rotating.
- 2) Lift the red ball knob (attached to horizontal rod behind engine) and push towards the machine. Locate the rod between the two nuts in the slotted catch plate.
- 3) Once in position the dog drive is disengaged.

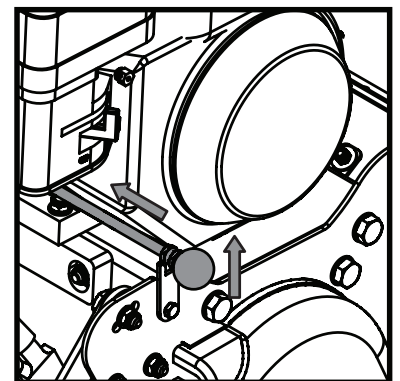

To re-engage the dog clutch:

- 1) Reduce engine revs to tickover as above (1).
- 2) Lift control rod clear of the locating slot and allow it to spring back towards you.
- 3) Slowly increase engine revs until an audible click is heard when the dogs engage. Alternatively rotate the black clutch drum about half a turn by hand and the same click will be heard. Do not rev the engine until the rod has moved right across and fully engaged.



## **NOTE**

**TO ASSIST THE SLOWING OF THE BLACK CENTRIFUGAL CLUTCH DRUM APPLY THE BRAKE BAND LEVER.**

## STARTING THE ENGINE

Once the preparatory steps have been completed as outlined on page 7 the engine may be started. (See manufacturer operating manual for full details).

- 1) Switch on the fuel tap.
- 2) Switch the handlebar cut off switch to **ON**, or depress deadmans handle (Item 1)
- 3) Set the throttle control to a half open position.
- 3) Shift the choke lever to the appropriate position (Kubota engine set to **START** : Honda engine set to the **CLOSE** position). The choke is not required if the engine is warm or the air temperature high.
- 4) Grasp the recoil start handle until resistance is felt, then pull it with force.
- 5) Do not allow the starter grip to snap back against the engine. Return it gently to prevent damage to the starter.
- 6) Once the engine is started gradually 'open' the choke lever (move the lever towards the **RUNNING**, or **OPEN** position). Warm-up running of 3-5 minutes is recommended.

## STOPPING THE ENGINE

- 1) Set the throttle control to the **CLOSED** position.
- 2) Switch the handlebar cut off to **OFF** or switch off at engine.
- 3) Close the fuel tap.

## TO COMMENCE MOWING

With the starting preparations completed and all of the adjustments from the 'General Adjustments' section made, the machine can be put into motion.

Firstly ensure the dog clutch is engaged. Open the throttle control on the left handlebar which will engage the inertia clutch and spin the cassette reel. The engine speed controls the rotational velocity of the cassette. Set the throttle to an approximately half open position.

To engage the rear roller drive, gently raise the driving clutch lever on the right handle bar (Item 2). The amount of depression on the lever dictates the speed of travel giving the operator total control over the speed and handling of the mower.

When the handle is released the machine will stop. To stop the unit head rotating, reduce the throttle to tick over and this will disengage the inertia clutch.

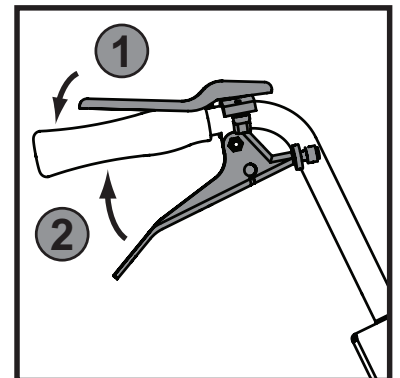



## SETTING FOR HEIGHT OF CUT

Always stop the engine before adjusting the height of cut. Failure to do this may result in severe injury.

The length of grass after cutting, or depth of scarification / dethatching / brushing, depends on the setting of the front roller in relation to the main frame of the machine.

### FT

The Click system allows easy adjustment of the front roller position each click representing a change of 0.5mm (0.020"). The roller is set to be equal on leaving the factory so when the arrows point forward on both decals the roller is level.

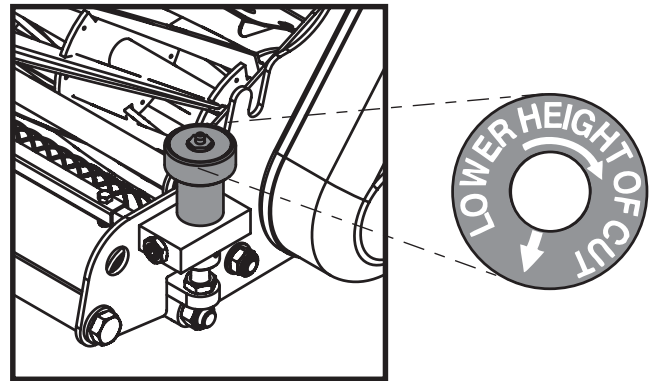

### SUPER SIX

Adjustment to the height of the front roller is on the quadrant brackets at each end of the roller outside the main frame assembly. Undo the adjuster knob on each side of the mower and move the roller up or down and then re-tighten the knobs. There are notches in the quadrant plates which must correspond with the hole in the side plate on both sides of the mower to ensure the roller is level.

Check it is level using the setting bar between the front and rear roller with the underside of the screw leading on the bottom blade.

Either a ruler or pile of coins can be used to set the setting bar to the correct position. You are measuring the distance between the bar and the underside of the button head screw ('XX' in the Image below).

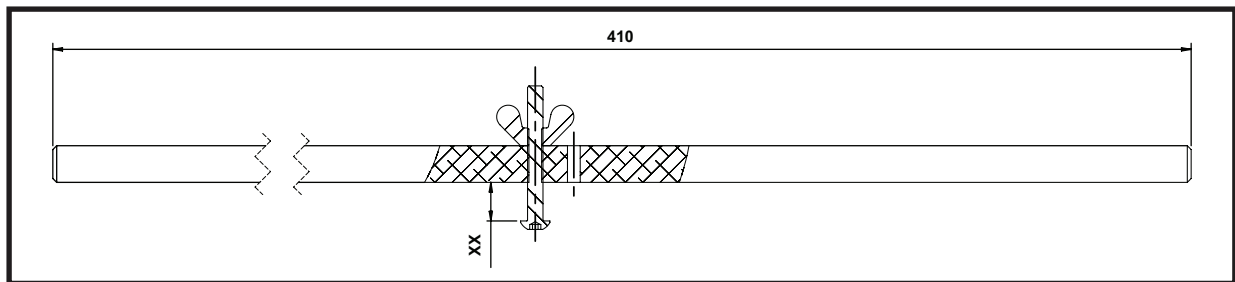

As an indication coins measure the following:-

- |                       |                       |                         |
|-----------------------|-----------------------|-------------------------|
| - 1p 1.58mm (0.063")  | - 2p 1.80mm (0.071")  | - 5p 1.73mm (0.067")    |
| - 10p 1.84mm (0.072") | - 50p 1.84mm (0.072") | - £1.00 3.14mm (0.124") |

Remember height of cut is effected by moisture of turf , weight of machine and the thatch density. Different makes of machine cut at different heights when set to the same position with the setting bar. We suggest you set it to a couple of mm above your planned height and then come down in height by trial.

If on setting the height of operation you find it needs altering once on the green simply click the adjusters up or down the same on each side until the desired height of operation is achieved.

Always check height of cut/operation with the setting bar provided. Check in two positions i.e. one at either end of the cassette. Failure to do this could result in an uneven cut.

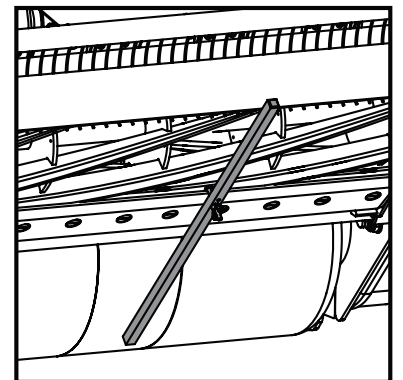

### NOTE

**DO NOT ATTEMPT TO USE THE DETHATCHER CASSETTE OR BRUSH CASSETTE ON TOO LOW A SETTING AS THIS WILL DAMAGE THE BLADES AND BRUSH. DO NOT ATTEMPT TO SCARIFY ON A LOW SETTING WHEN GROUND CONDITIONS ARE DRY AS THIS MAY CAUSE THE CENTRIFUGAL CLUTCH TO SLIP.**

## CUTTER SETTING ADJUSTMENT

For cutter cylinder cassettes (5 or 9 blade units).

For a full view of the setting operation we suggest you remove the cassette from the machine and place on the back flat edge of the frame at a comfortable height. It is now possible to make adjustments in the machine without cassette removal should you prefer.



### **WARNING**

*CYLINDERS AND BOTTOM BLADES ARE SHARP, WEAR GLOVES TO PROTECT YOUR HANDS AND FINGERS.*

The FT cylinder is fixed in position in self-aligning bearings with aluminium housings spigotted to the side frames. The bottom blade assembly is adjusted up and down by using a knurled knob system.

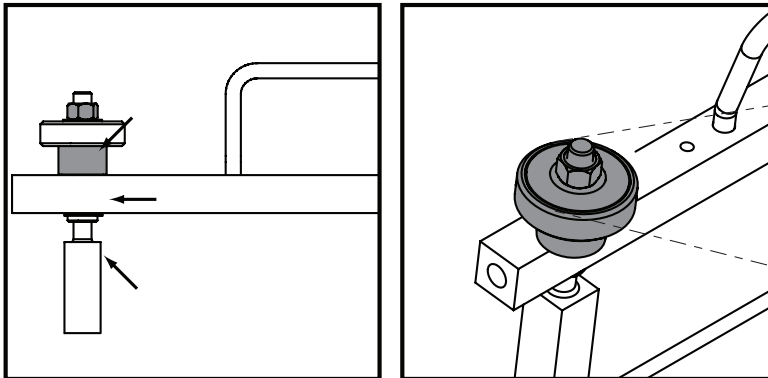

To operate this system firstly slacken the two locknuts

on the adjuster stems – The Lock Nut (A) is directly on top of the Knurled Knobs (B). Use a 9/16 AF spanner. Each knurled knob has a decal to indicate **ON** or **OFF** cut. **ON** cut brings the bottom blade closer to the cylinder. **OFF** cut moves it away.

**A = Locknut (9/16" Spanner)**

**B = Lubricate occasionally with Oil**

**C = Circlip**

Rotate the knurled knobs to gain light contact between the shear blade and cylinder on both sides of the cassette. The adjustment should be made so that the cylinder will spin with a light audible contact with the bottom blade. Check the setting using thin paper along the length of the cylinder adjusting until it cuts along its whole length.

When a satisfactory set is achieved tighten the lock nuts whilst holding the knurled knob firmly (to stop it turning), recheck adjustment.

Do not set the cylinder hard on, as this will cause excessive wear of the cylinder, bottom blade the drive system and increase fuel consumption.

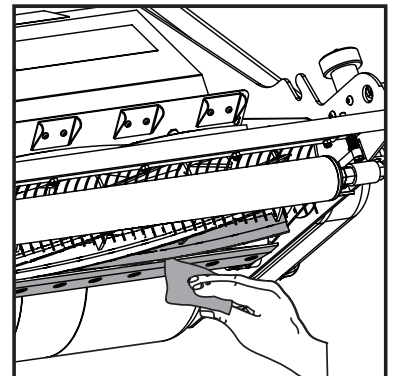

## HANDLEBAR ADJUSTMENT

The height of the Handle Bars can be adjusted to suit various operators. Follow the below instructions:-

1. Remove Bolt (Item 1) on both sides of the machine.
2. Select the require position out of the 3 available.
3. Replace the Bolt on both sides of the machine.

## GRASS BOX

If using the grass box, place the two locating tabs (projecting from the grass box support plates) into the slots on the machine side plate. Lower the front of the box until the box support plate's rest on the front cross bar of the machine. Ensure both box support plates are properly located before proceeding.

Always disengage the cassette drive before removing the grass box for emptying or access by reducing the engine revs to tick over. Wait for the cutter to stop before removing.

Always keep fingers away from the cassette when the engine is running. Stop the machine before making any adjustments.

Hold the grass box firmly on the lip of the aperture and place the other hand in the handle on the front edge of the box.

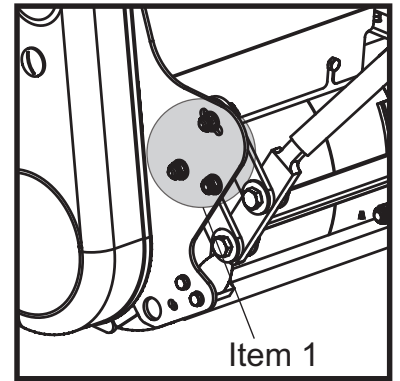

## Removing The Cassette Unit

To remove the cassette unit for maintenance or to exchange cassettes the following procedure should be followed:-

- 1) Unscrew the hand wheel of the retaining pin for about half-an-inch (13mm) until the pip end is inside the nut on the side frame.
- 2) Slide the cassette unit along the tie bars as far as it will go until the cutter nut and coupling is clear of the three pins in the driving coupling.
- 3) Remove the unit from the chassis by lifting in a swinging motion from the back.

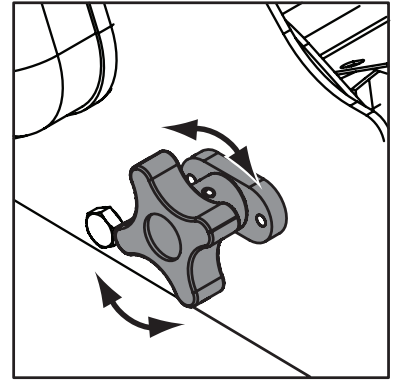

To replace the cassette unit :-

- 1) Place the front slots of the cassette unit frames on the two front retaining pins seen projecting from inside each frame.
- 2) Carefully lower the unit in a downward swinging motion until the rear slots of the cassette unit frame rest on the cross tie bar.
- 3) Move in a lateral direction away from the retaining pin until the three holes of the cassette nut and coupling are in full engagement with the three pins of the driving coupling.
- 4) Screw up the hand wheel with the retaining pin, engaging the hole in the side frame on the opposite side. Do not over tighten.

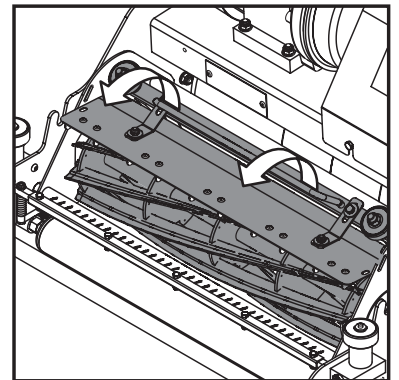
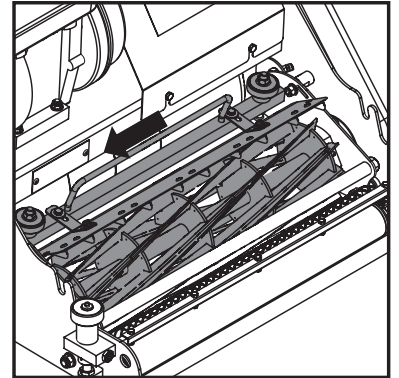

## ENGINE

The FT is fitted with a Honda GX160 (GX120 on FT 430) petrol engine. All are single cylinder, overhead valve, 4 stroke, forced air cooled engines. For full specifications please refer to the manufacturers instruction manual included.

Area	Maintenance	First 4 Hours	First Month / 20 Hours	3 Months / 50 Hours	6 Months / 100 Hours
Engine Oil	Check Level	✓			
Engine Oil	Change		✓		✓
Air Filter	Check Condition / Clean		✓		✓
Spark Plug	Change				✓

## OIL / FUEL TYPE & QUANTITY - SPARK PLUG TYPE

Engine Model	Oil Type	Quantity (Ltr)	Fuel Type	Capacity (Ltr)	Spark Plug Type	Electrode Gap (mm)
Honda GX120 & GX160 Petrol	SAE 10W-40	0.6	Unleaded	2.5	BM6ES or BPR6ES	0.7 - 0.8

## DRIVING BELTS

The main drive to both rear roller and cassette is via hard wearing TBA poly-V type belts which provide for smooth trouble free operation. To ensure the best performance the following instructions should be carefully followed.

Belt tension is the single most important factor necessary for long, satisfactory service life of any belt drive.

Under-tensioning leads to belt slip causing rapid wear; over tensioning means excessive strain on belt and bearings. Between these two extreme conditions is a reasonable range of tension within which the belt will operate. Belt tension can be assessed by the 'deflection' method.

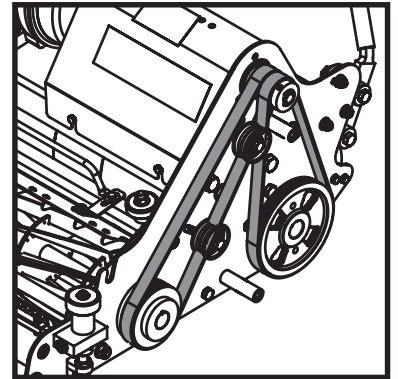

### **NOTE**

*CORRECTION CAN BE MADE BY ADJUSTMENT OF THE BELT TENSIONERS. REMOVE THE DRIVING BELT COVER. THE BELT TENSIONERS ARE RETAINED IN A SLOTTED HOLE ALLOWING ADJUSTMENT TO BE MADE ONCE THE HOLDING HEXAGON HEADED BOLTS HAVE BEEN LOOSENED. WHEN ADJUSTED CORRECTLY THE TENSIONERS SHOULD STILL ROTATE EASILY WITH FINGER PRESSURE. ENSURE THE TENSIONER BOLTS ARE SECURE BEFORE REPLACING THE COVER.*

"Belts will be sufficiently tensioned if the deflection force applied at mid span to produce a deflection equal to 16mm per meter of span distance falls between 5 and 9 Newtons per Rib" (TBA Belting).

In practical terms this relates to about 5mm of deflection under moderate finger pressure on the non tensioner side.

If fitting new belts it is advisable to observe the drive for the first 20-30 minutes. It may be necessary to make an adjustment to compensate for the normal drop in tension during the run-in period.

### **FOR BELT DETAILS, REF. 1.02 (Pg. 19)**

Do not overtighten belts as this may cause excessive wear on the dog clutch.

### **BRAKE BAND ADJUSTMENT (Rear Axle Drive)**

The brake band assembly is mounted on the end of the rear axle spindle on the right hand side of the machine. The assembly comprises a cast iron drum inner member, which is stopped or braked with a lined steel brake band. This operates dry and no lubrication of any kind is required.

Adjustment is provided for tightening the band on the inner member should this be necessary through wear. The procedure to take up any slack is as follows :-

1. Remove the clutch cover by unscrewing the two hexagon headed screws seen on the outside of the cover.
2. Unscrew the lock nut on the adjuster screw situated between the two clutch band lugs.

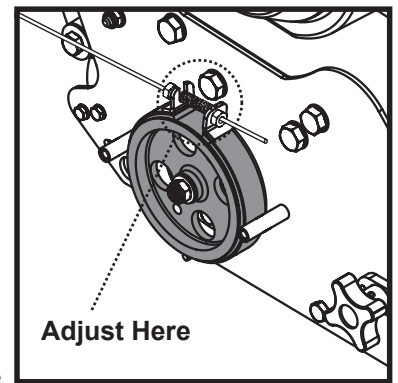

#### **NOTE**

*ENSURE THE LOCK NUTS ARE TIGHT AND SECURE AND CHECK OPERATION IS SATISFACTORY BEFORE REPLACING THE CLUTCH COVER AND SCREWS.*

Adjustment of the brake band can be set to suit your preference but always ensure that there is sufficient free play so that when the engine revs are increased the machine does not move in any way until the lever is pulled up.

On some models there is adjustment on the handle grip itself to allow any wear to be taken up.

## **REAR ROLLER**

The centre section gear case chamber of the rear roller is an assembly in two halves and contains the epicyclic gear system, which runs in an oil bath.

The chamber is charged with gear oil EP 90 before the machine leaves the works and should require no further filling during the cutting season. If in every day use then a topping up charge of about one egg cup full every two months may be appropriate.



**WARNING** ***DO NOT OVERCHARGE.** AT NO TIME SHOULD THERE BE MORE THAN 100CC OF OIL IN THE CHAMBER.*

Access to the chamber is gained by unscrewing the hexagon screw found in the recess of the centre section of roller. Clean away all dirt and grit before removing this screw. On replacing the screw, make sure it is tight and secure.

Recommended grade gearbox oil EP90.

## **RATCHET PAWLS AND DRUM HUBS OF THE REAR ROLLER (Every 2 Months)**

Projecting from the side face towards the centre of each outer drum will be seen two grease nipples which provide access for lubrication to the rear roller driving pawls and the drum hub bearing sleeve.

A small charge of light grease should be applied every two months.

## **FRONT ROLLERS**

The bearings used on the front rollers are pre packed with grease and rubber shielded, therefore requiring no additional greasing.

## **CYLINDER CASSETTE BEARINGS (Every Day)**

To apply lubrication to the cylinder cassette bearings it is first necessary to remove the cassette unit from the chassis as described on page 9.

Projecting from each bearing cover will be seen a grease nipple through which a small charge of grease should be applied using the grease gun

**MEDIUM GREASE = GOOD QUALITY**

## **SCARIFIER / DE-THATCHER / BRUSH CASSETTES**

No grease or oiling is required.

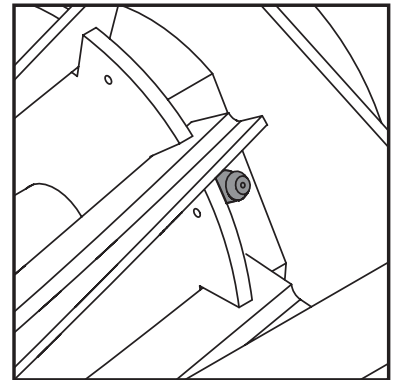
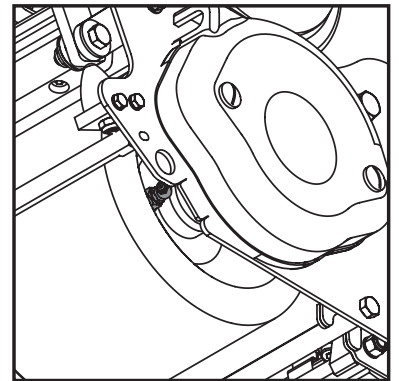

### **DOG DRIVE (Every Day) - VERY IMPORTANT**

Apply a small squirt of lubricating oil (2-3 drops) directly into each hole in the top of the drive shaft cover. This keeps the clutch slippers lubricated.

### **CONTROL LEVERS AND CABLES (Every 2 Months)**

To keep the controls free from rust and corrosion apply a small charge of oil to the throttle and clutch control levers every two months. Oil flow can be assisted by working the levers open and closed a few times after the lubrication is applied.

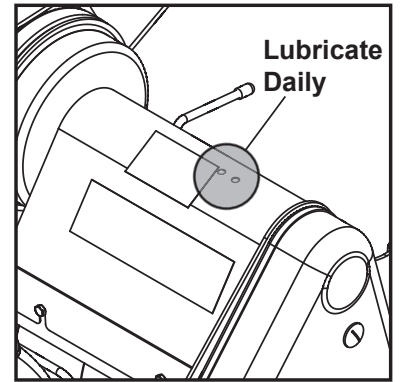

### **FRONT ROLLER ADJUSTERS (Every 2 Months)**

Apply a small quantity of copper grease or similar to the adjuster studs to prevent corrosion and ease adjustment.

## Storage

The machine should always be kept in a clean dry place, free from condensation. After use ensure that the machine is thoroughly clean, dry and free from grass and mud. Before off season storage smear a thin layer of grease on to the cutter blades and the shear blade.

Under no circumstances must the machine be steam cleaned as this may remove grease from the pre packed bearings.

Because of the nature of lead free petrol we recomend that if the machine is being left unused for more than 2 weeks the carburetor is run dry. Allow the engine to run out of fuel with the fuel tap switched off.

## Guide To Replacement Parts



### **NOTE**

*WHEN ORDERING PARTS PLEASE QUOTE YOUR MACHINE SERIAL NUMBER AND ENGINE NUMBER. A BOX TO ENTER THESE FOR EASY REFERENCE IS AT THE BEGINNING OF THE MANUAL.*

This manual contains listing of parts for the Dennis FT430, FT510 and FT610 machines. An illustration of the parts as an assembly is shown above the list.

Where parts are given a description of LH or RH (left hand or right hand) this is as viewed from the users position.

The Parts Listings for FT Range can be found in this manual from page 18 onwards.



## **9 BLADE CYLINDER (SEE PAGE 34)**

- For cutting fine turf areas.
- Three bottom blade options.
- Comb active or passive.

## **5 BLADE CYLINDER (SEE PAGE 34)**

- For general purpose cutting.
- Comb active or passive.

Settings - Expressed as above and below ground level i.e. by placing the setting bar between the front and rear rollers, the top of the bar represents ground level.

## **VERTICUTTER (SEE PAGE 39)**

Used from ground +3mm to ground -3mm to control thatch, cutting lateral growths and standing up lying grasses ready for cutting and lifting with the comb. Good for removing mosses. Start on the green at (say) +3mm.



**NOTE**    *NOT FOR CUTTING SOIL, ONLY THATCH.*

**RESULT** - Speed improvement on greens, reduced end of season maintenance. Promotes healthy plant growth, promotes strong roots, and maximizes fertilizer penetration.

## **SCARIFIER (SEE PAGE 36)**

Used for ground to ground -10mm controlling thatch, removing thatch, cutting lateral growth, pruning roots, removing moss, aerating top layer for ingress of water, air, fertilizer and seed. Choice of 1mm or 2mm thick blades (generally 1mm used in summer, 2mm used in winter). Do not try to cut too deep - must be adjusted to suit conditions. Keep engine revs reasonably high with a slow forward movement to remove as much material as possible. The machine may tend to walk along on its own in some conditions.

**RESULT** - Speed increase of playing surface. Maximizes fertilizer penetration & promotes strong healthy plant growth and strong roots.

## **BRUSH (SEE PAGE 35)**

Used for light scarifying, brushing, removing debris, cigarette ends, pine needles moss, excess top dressing etc. Set at +3mm to +1mm for ground debris depending on conditions. Remove comb.

## **IRONING ROLLER NON DRIVEN (NOT SHOWN)**

Ballastable for extra weight. Used for ironing greens. Set level or lift up front roller.

## **SORREL ROLLER NOT DRIVEN (SEE PAGE 38)**

Used for surface pricking. Lets air, water, fertilizer into the root zone. Good for over seeding and preparing damaged areas for repair. Reduces surface tension.

	Bowls	Cricket	Golf
Verticutter	Monthly	Fortnightly	Monthly
Scarifier	1 - 2 Months	1 - 2 Months	1 - 2 Months
Brush	As Required	As Required	As Required
Ironing roller	Match Days	Pre-Season	As Required
Sorrel Roller	1 - 2 Weeks	Monthly (As Required for Repair)	Monthly (As Required for Repair)

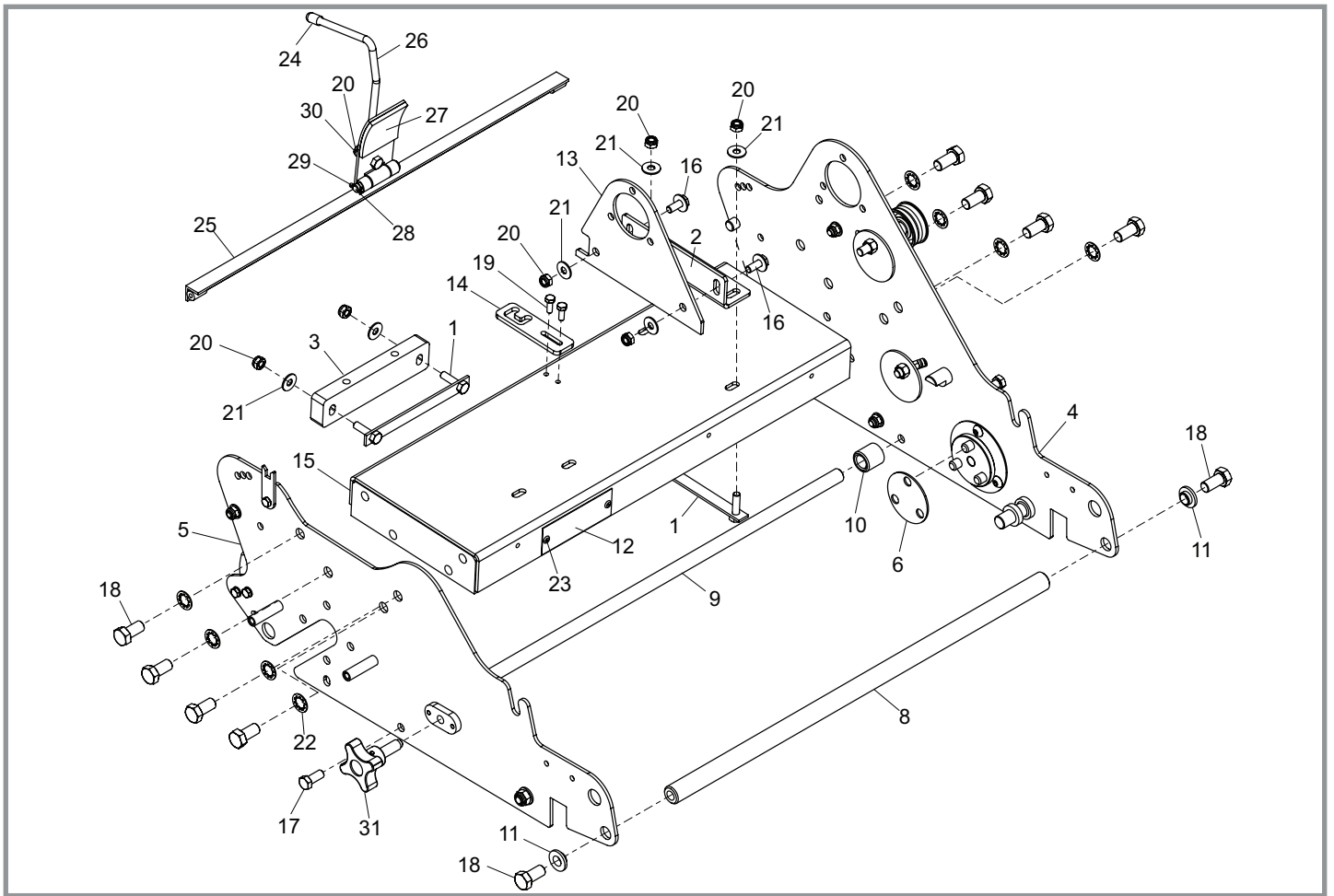

# 1.01

# Chassis - Main Assembly

Item No.	Part No.	Description	Quantity	Item No.	Part No.	Description	Quantity
1	229492	Retaining Plate Assy	2	29	SP05010	Split Pin 1/8" x 1"	1
2	230004	Support Bracket	1	30	SP03008	Washer M8 Form A	1
3	230006	Support Plate Engine	1	31	800104	Cassette Retaining Screw	1
4	See 1.02	FT L.H. Side Plate Assembly	1				
5	See 1.03	FT R.H. Side Plate Assy	1				
6	J20222	Cork Buffer	1				
7	800104	Stop Pin Assy	1				
8	J17235	Front Cross Bar (17")	1				
8	J20235	Front Cross Bar (20")	1				
8	J24235	Front Cross Bar (24")	1				
9	J17236	Lower Unit Tie Bar (17")	1				
9	J20236	Lower Unit Tie Bar (20")	1				
9	J24236	Lower Unit Tie Bar (24")	1				
10	J20263	Front Stud Spacer	1				
11	J20292	Collar Front Tie Bar	2				
12	J20297	Serial Number Plate	1				
13	J209053	Support Plate	1				
14	J209059	Gate	1				
15	J179215	Engine Bed (17")	1				
15	J209215	Engine Bed (20")	1				
15	J249215	Engine Bed (24")	1				
16	SP01009	Hex Set Screw M8 x 20	2				
17	SP01011	Hex Set Screw 3/8" UNF x 3/4"	2				
18	SP01053	Hex Set Screw 1/2" UNF x 1"	10				
19	SP01055	Hex Taptite Screw M6 x 16	2				
20	SP02006	Nut M8 Nyloc	7				
21	SP03015	Washer M8 Form C	8				
22	SP03023	Washer 1/2" Toothed	8				
23	SP05001	Rivet 4.8 x 10	2				
24	228094	End Tip 5/16"	1				
25	J17251	Rear Scraper Bar Assy (17")	1				
25	J20251	Rear Scraper Bar Assy (20")	1				
25	J24251	Rear Scraper Bar Assy (24")	1				
26	J209056	Hand Brake Lever	1				
27	J209057	Brake	1				
28	SP05014	Clevis Pin 3/8" x 2 1/2"	1				

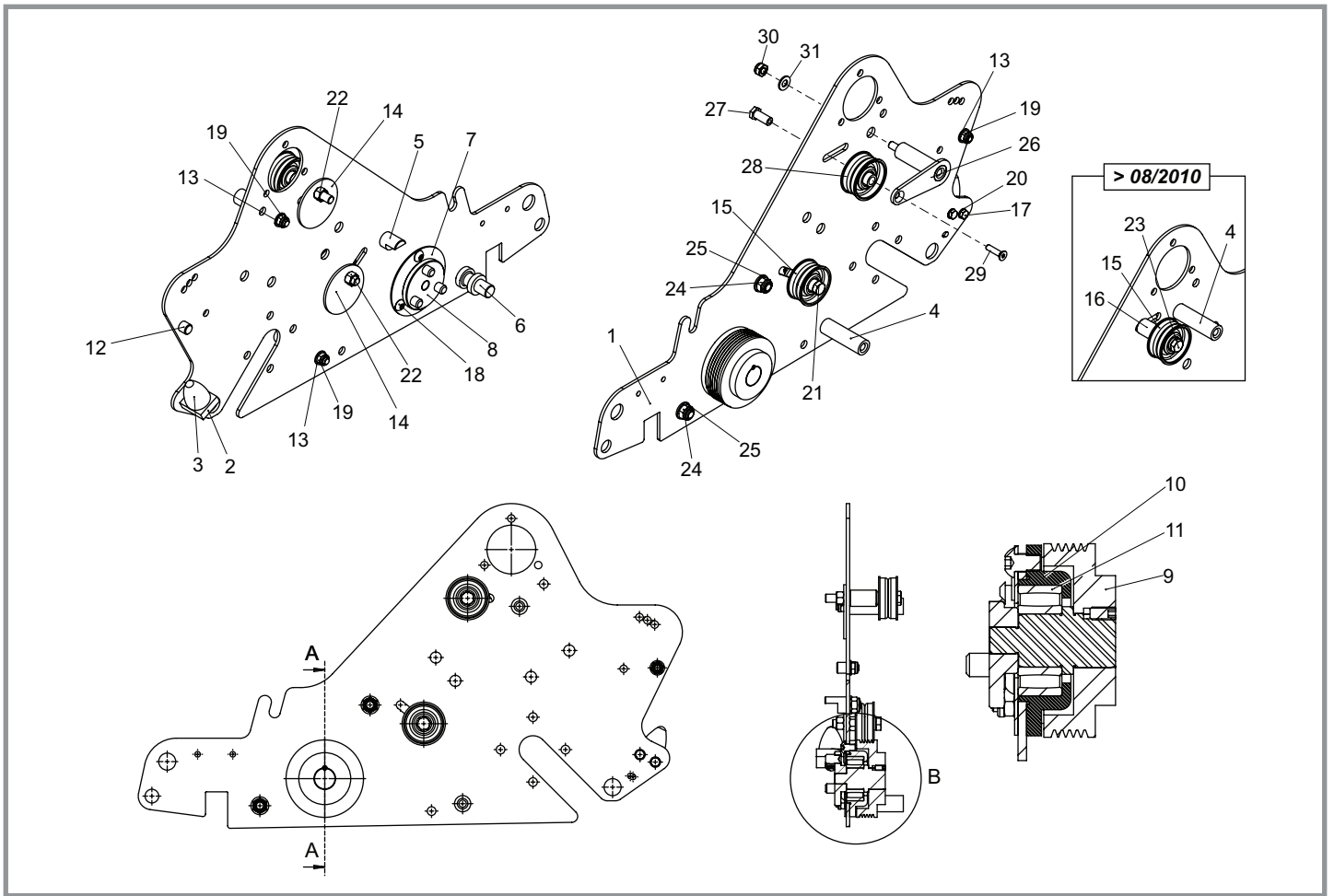

## 1.02

## Chassis - LH Side Plate (800020)

Item No.	Part No.	Description	Quantity	Not Shown			
1	J209253	Side Plate LH (FT)	1	-	J209003	3 Groove Drive Belt (Rear Roller)	1
1	J209218	Side Plate LH (Super Six)	1	-	J209005	5 Groove Drive Belt (Cylinder)	1
2	229741	Buffer Block	1				
3	229742	Buffer	1				
4	J209072	Chain Case Stud (> 08/2010)	2				
5	J20216	Unit Limiting Stud	1				
6	J20238	Shoulded Bearing Stud (FT)	1				
6	J209110	Unit Bearing Stud (Super Six)	1				
7	J20008	Back Plate With Hole	1				
8	J20221	Male Coupling	1				
9	J209203	Cassette Driven Pulley / Shaft	1				
10	J209206	Cassette Drive Bearing Housing	1				
11	J20255	Bearing 5205 - 3205 2RS	1				
12	J20023	Unit Limiting Stud	1				
13	SP03008	Washer M8 Form A	3				
14	J209043	Tensioner Back Plate	2				
15	J209047	Tensioner Pulley (> 08/2010)	2				
16	J209049	Spacer Roller Tensioner (> 08/2010)	1				
17	SP01008	Hex Set Screw M6 x 16	2				
18	SP01012	Button Head M8 x 12	3				
19	SP02006	Nut M8 Nyloc	4				
20	SP03003	Washer M6 Toothed	2				
21	SP01013	Hex Set Screw 3/8" UNF x 2"	1				
22	SP02015	Nut 3/8" UNF	3				
23	SP01057	Screw 3/8" UNF x 3 1/4" (> 08/2010)	1				
24	SP02008	Nut M10 Nyloc	2				
25	SP03011	Washer M10 Form A	2				
26	230490	Belt Tensioner (< 08/2010)	1				
27	230493	Pulley Retainer (< 08/2010)	1				
28	J209047	Tensioner Pulley (< 08/2010)	1				
29	SP01056	CSK Cap Head M6 x 25 (< 08/2010)	1				
30	SP02006	Nut M8 Nyloc (< 08/2010)	1				
31	SP03008	Washer M8 Form A (< 08/2010)	1				
32	800222	Belt Tensioner Assembly (< 08/2010) (Includes Items 26, 27, 28, 29, 30, 31)	1				

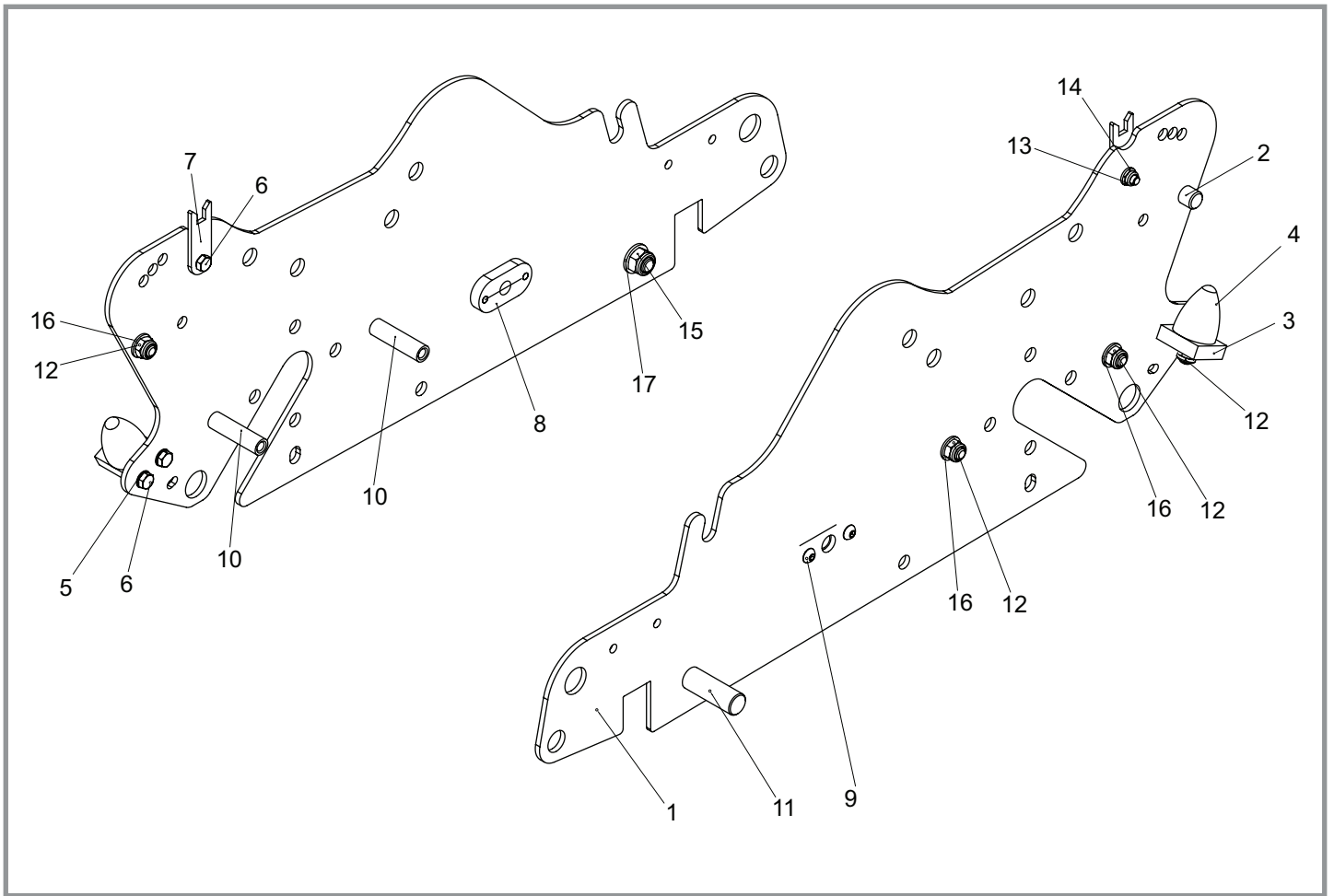

## 1.03

## Chassis - RH Side Plate (800021)

Item No.	Part No.	Description	Quantity
1	J209254	Side Plate RH (FT)	1
1	209219	Side Plate RH (Super Six)	1
2	J20023	Unit Limiting Stud	1
3	229741	Buffer Block	1
4	229742	Buffer	1
5	SP03003	Washer M6 Toothed	2
6	SP01008	Hex Set Screw M6 x 16	3
7	J209229	Clutch Rod Stop	1
8	J209078	Retaining Screw Plate	1
9	SP01016	Button Head M6 x 12	2
10	J20207	Stud Brake Band Cover	2
11	J20237	Unit Bearing Stud (FT)	1
11	J209110	Unit Bearing Stud (Super Six)	1
12	SP02006	Nut M8 Nyloc	4
13	SP02004	Nut M6 Nyloc	1
14	SP03010	Washer M6 Form A	1
15	SP02008	Nut M10 Nyloc	1
16	SP03008	Washer M8 Form A	3
17	SP03011	Washer M10 Form A	1

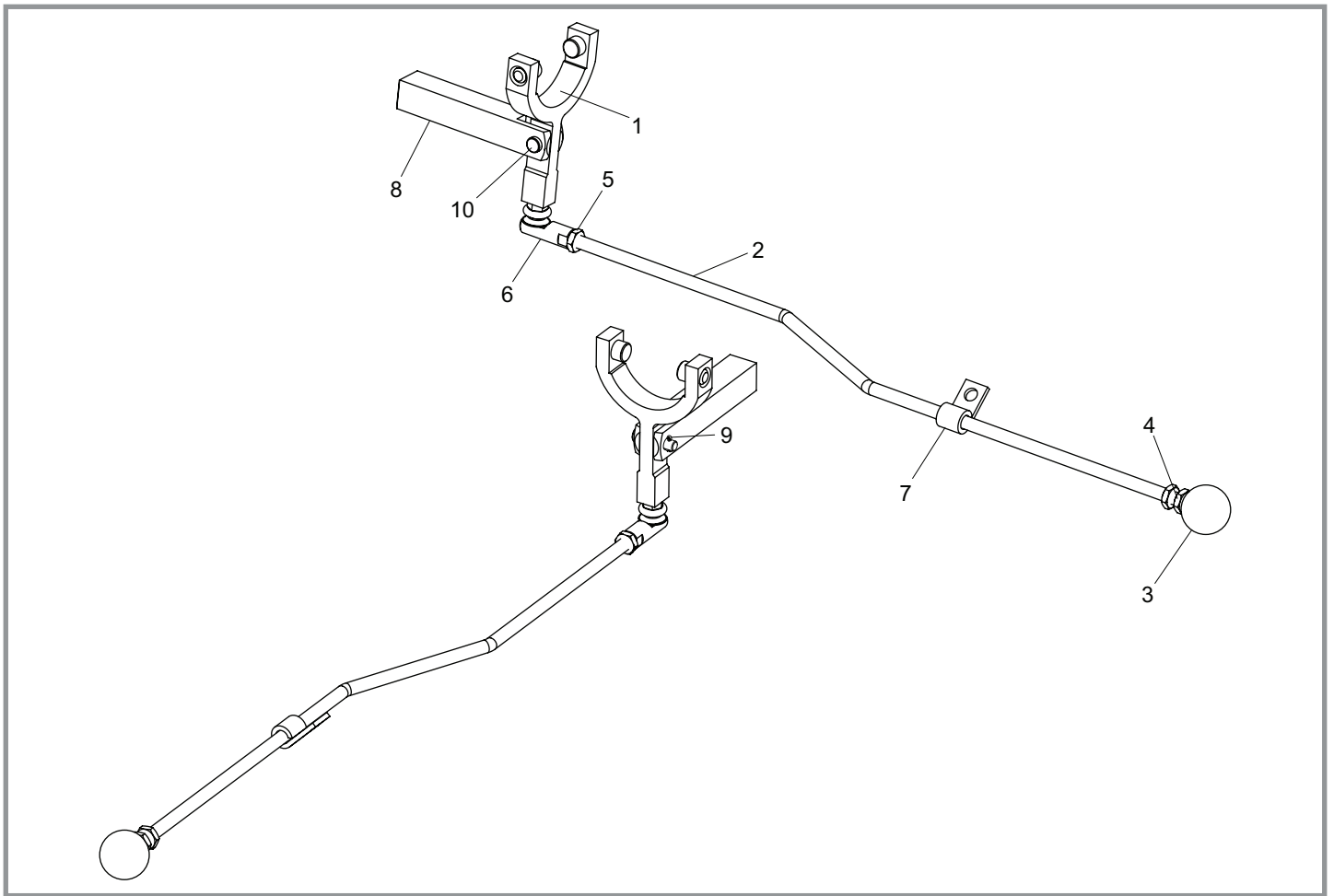

## 2.01

## Cutter Engagement - Main Assembly

Item No.	Part Number	Description	Quantity
1	J209230	Dog Clutch Fork Assy.	1
2	J179231	17" Clutch Control Rod	1
2	J209231	20" Clutch Control Rod	1
2	J249231	24" Clutch Control Rod	1
3	J20017	Knob - Red	1
4	J209024	Nut 5/16 BSF Lock (Thin)	2
5	J209026	Nut 5/16 UNF Lock (Thin)	1
6	J209019	Rod End	1
7	J209232	Bracket Control Rod	1
8	J209226	Clutch Fork Pivot Mounting	1
9	J209021	Split Pin 1/16" x 1/2"	1
10	J209020	Pin Clevis	1

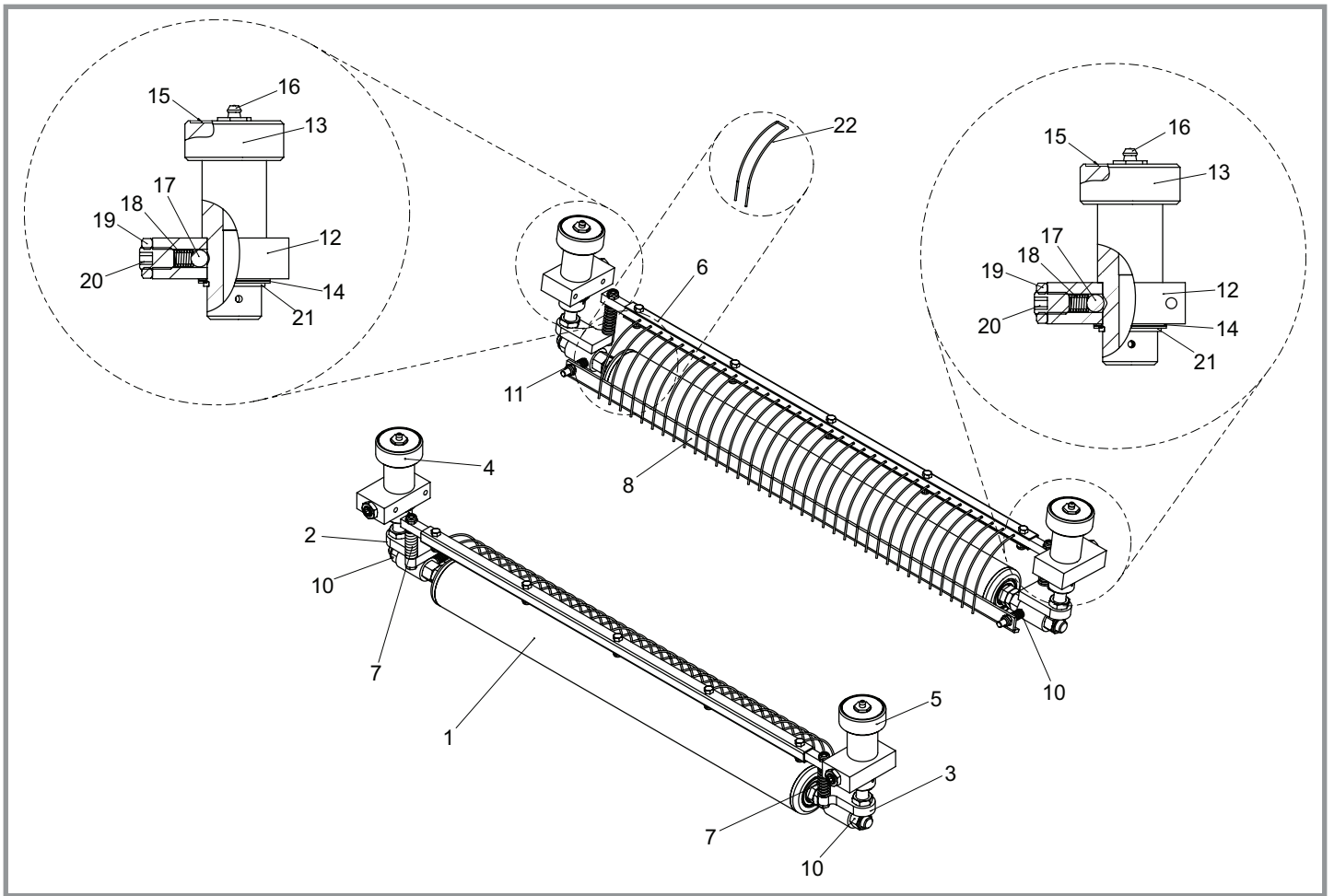

### 3.01

### FT Front Roller - Main Assembly

Item No.	Part No.	Description	Quantity
1	800002	Front Roller Assy 17"	1
1	800502	Front Roller Assy 20"	1
1	800503	Front Roller Assy 24"	1
2	J20522	End Block RH	1
3	J20521	End Block LH	1
4	800149	Click Height Adjuster RH	1
5	800148	Click Height Adjuster LH	1
6	800182	Comb Bar Sub Assy 17"	1
6	800180	Comb Bar Sub Assy 20"	1
6	800181	Comb Bar Sub Assy 24"	1
7	J20510	Spring Comb Bar	2
8	J17250	Front Roller Scraper Bar 17"	1
8	J20250	Front Roller Scraper Bar 20"	1
8	J24250	Front Roller Scraper Bar 24"	1
9	J20505	Spring Scraper	2
10	SP02010	Nut M12 Nyloc	2
11	SP02004	Nut M6 Nyloc	4
12	J20517	Ht. Adjuster Block	1
13	J20518	Height Adjuster Knob	1
14	228092	Shim Id 25.8 x 1 Thk	2
15	J20519	Decal Height Of Cut	1
16	J20528	Grease Nipple 1/4" Bsp	1
17	J20525	Steel Ball 8mm	1
18	J20526	Spring	1
19	SP02013	Nut M10 Lock (Thin)	1
20	SP01018	Grub Screw M10 x 16	1
21	SP07007	Circlip D1460 - 25	1
22	J20509	Comb Tine	AR

#### Not Shown

-	SP01016	Button Head Screw M6 x 12	4
-	J209105	Front Roller Bearings	2
-	J209073	Front Roller Oil Seal	2
-	J17502	Front Roller Shaft 17"	1
-	J20502	Front Roller Shaft 20"	1
-	J24502	Front Roller Shaft 24"	1

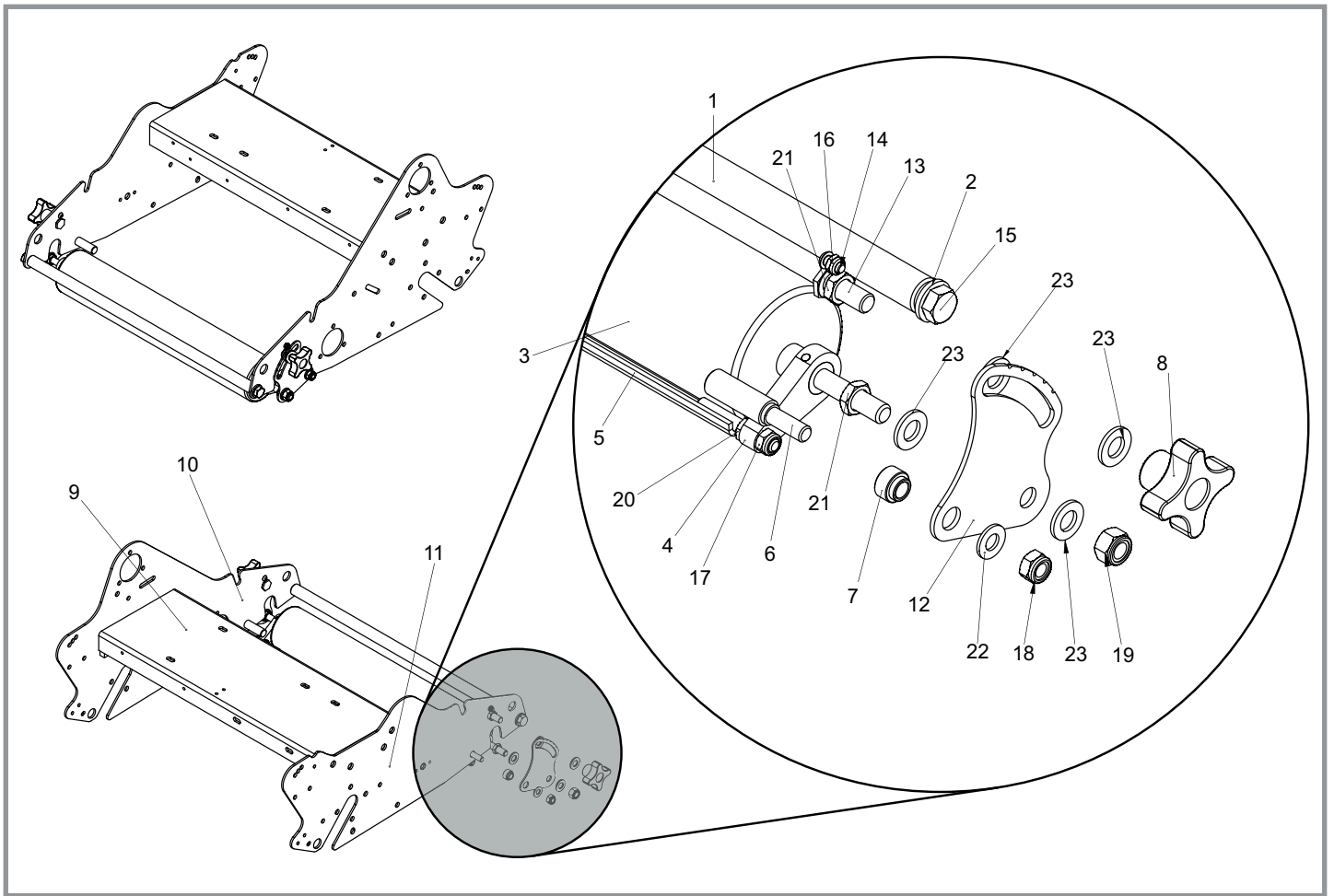

### 3.02

## Super Six Front Roller - Main Assembly

Item No.	Part No.	Description	Quantity
1	J20235	20" Front Cross Bar	1
1	J24235	24" Front Cross Bar	1
2	J20292	Collar Front Tie Bar	2
3	J20550	20" Front Roller	1
3	J24550	24" Front Roller	1
4	J20551	Scraper Bar Ear	2
5	J20552	20" SS Scraper Bar	1
5	J24552	24" SS Scraper Bar	1
6	J209110	Unit Bearing Stud	2
7	J209111	Bush Quadrant	2
8	J209112	Knob Plastic	2
9	J179215	Engine Bed 17"	1
9	J209215	Engine Bed 20"	1
9	J249215	Engine Bed 24"	1
10	J209218	Side Plate L.H. S.S.	1
11	J209219	Side Plate R.H. S.S.	1
12	J209225	Roller Quadrant S.S.	2
13	J209252	Lock Screw	2
14	SP01016	Button Head M6 x 12	2
15	SP01053	Hex Set Screw 1/2" UNF x 1"	2
16	SP02004	Nut M6 Nyloc	2
17	SP02006	Nut M8 Nyloc (T)	2
18	SP02008	Nut M10 Nyloc (T)	2
19	SP02010	Nut M12 Nyloc (T)	2
20	SP02012	M10 Thin Lock Nut	2
21	SP02014	Nut M12 Lock (Thin)	4
22	SP03011	Washer M10 Form A	2
23	SP03012	Washer M12 Form A	8

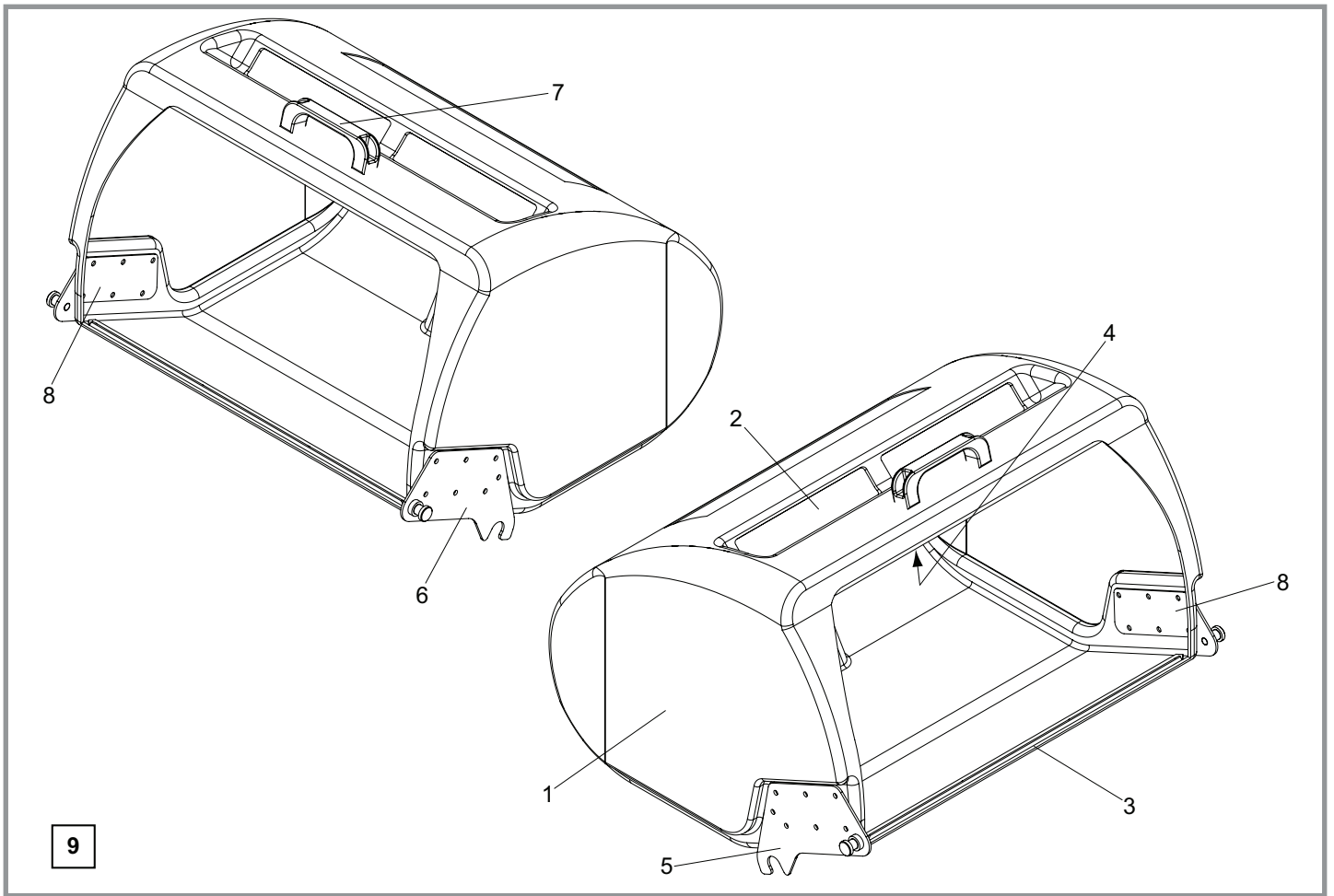

## 4.01

## Grassbox - Main Assembly

Item No.	Part No.	Description	Quantity
1	J179237	FT430 Grassbox Moulding	1
1	J209237	FT510 Grassbox Moulding	1
1	J249237	FT610 Grassbox Moulding	1
2	J209062	Mesh (FT510)	1
2	J249062	Mesh (FT610)	1
3	J17257	17" Grassbox Edging Strip	1
3	J209063	20" Grassbox Edging Strip	1
3	J249063	24" Grassbox Edging Strip	1
4	J209064	Handle Plate Grass Box	1
5	J209222	LH Grassbox Wing	1
6	J209224	RH Grassbox Wing	1
7	J209243	Handle Grassbox	1
8	J209060	Grassbox Support Plate	2
9	800008	17" Grassbox Complete	1
9	800017	20" Grassbox Complete	1
9	800042	24" Grassbox Complete	1

### Not Shown

-	SP04002	Screw M6 x 16 Slotted (To fit Item 5 & 6)	8
-	SP02004	Nut M6 Nyloc (To fit Item 5 & 6)	8
-	SP01008	Hex Set Screw M6 x 16 (To fit Item 7)	2
-	SP03007	Washer M6 x 20 (To fit Item 7)	2



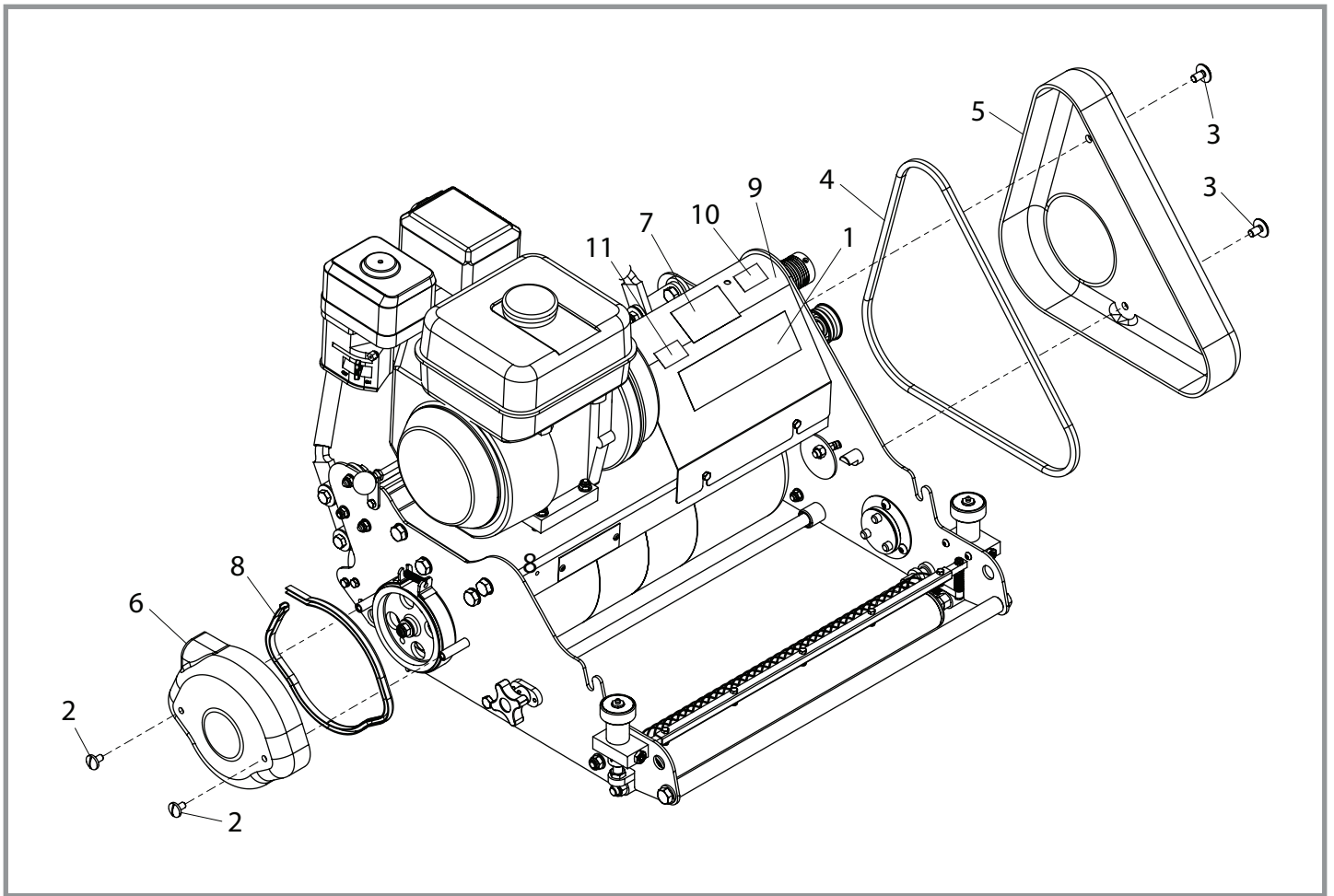

## 5.01

## Guards - Main Assembly

Item No.	Part No.	Description	Quantity
1	B32902	Decal Dennis	2
2	J209074	Brake Band Cover Screw	2
3	194946	Chain Case Screw	2
4	228031	Belt Guard Seal	1.23m
5	J20712	Belt Guard	1
6	J20206	Brake Band Cover	1
7	B32903	Decal Union Jack	1
8	228031	Brake Band Seal	0.62m
9	J179221	Transmission Cover 17"	1
9	J209221	Transmission Cover 20"	1
9	J249221	Transmission Cover 24"	1
10	B32904	Oil Daily Decal	1
11	229605	98dB Decal	1

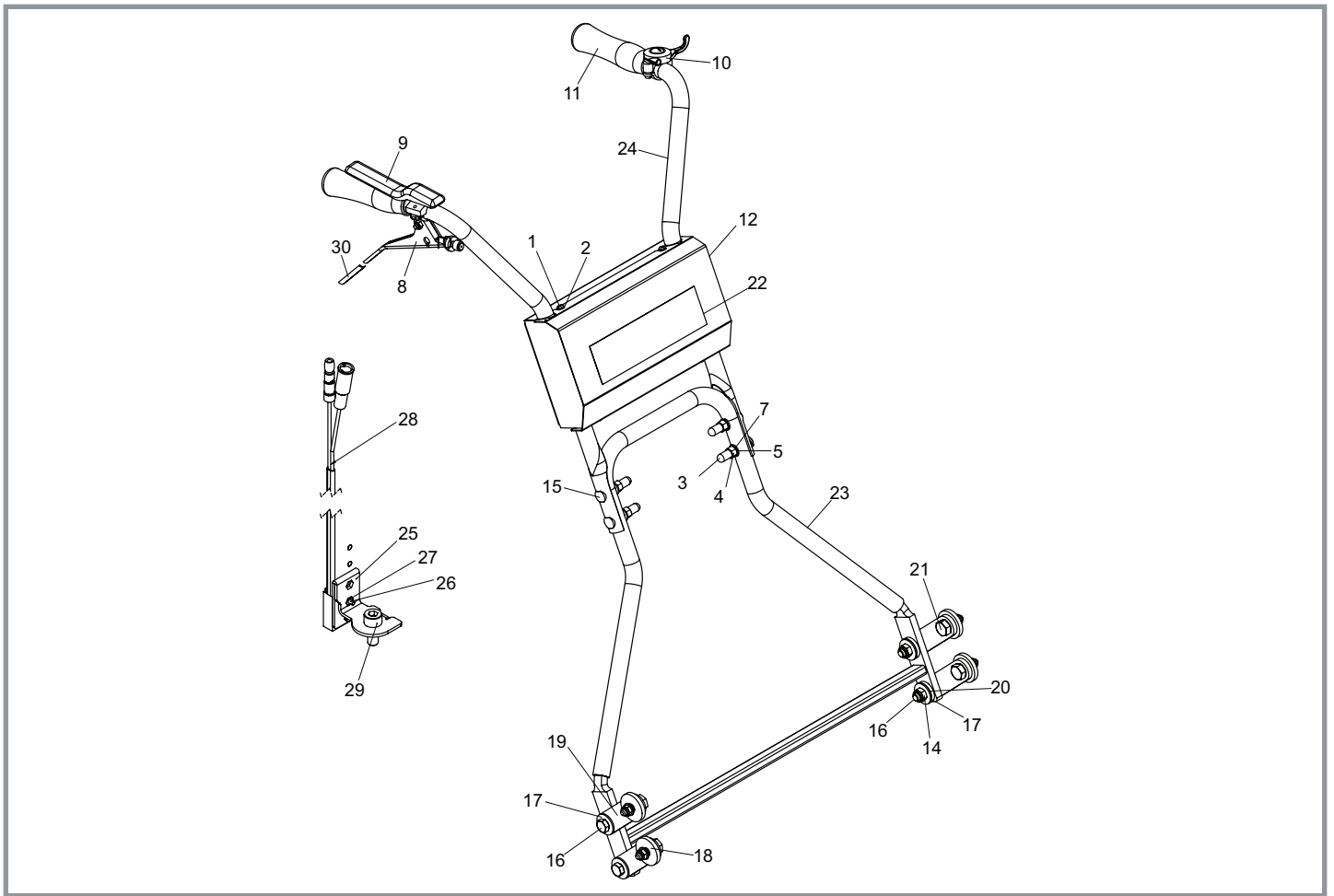

## 6.01

## Handle - Main Assembly

Item No.	Part No.	Description	Quantity	Not Shown		
1	SP04001	Screw M5 x 16 Slotted	4	-	J20112 Throttle Cable (Honds MKII & Kubota MKI)	1
2	SP03009	Washer M5 Form A	4	-	J20113 Brake Band Cable	1
3	228094	End Tip 5/16"	4	-	J20123 Electric Loom (Deadmans) (> 02/2012)	1
4	SP02005	Nut M8 STD	4	-	SP12021 Electric Loom (Deadmans) (< 03/2012)	1
5	SP03004	Washer M8 Toothed	3	-	J20110 Brake Band Lever Grip	1
6	SP03004	Washer M8 Toothed	1			
7	SP03008	Washer M8 Form A	8			
8	J20109	Brake Band Lever	1			
9	800514	Deadmans Handle Kit (> 02/2012)	1			
9	SP12010	Deadmans Lever (< 03/2012)	1			
10	J20108	Throttle Control Lever	1			
11	J20107	Handle Grip Rubber	2			
12	230013	Console Cover (No Switch)	1			
13	SP02006	Nut M8 Nyloc	4			
14	SP02008	Nut M10 Nyloc	4			
15	228093	Bolt Saddle M8 x 43	4			
16	SP01020	Hex Set Screw M10 x 40	4			
17	SP03018	Washer M10 Form G	8			
18	229724	Arm Pivot Bush	4			
19	229725	Pivot Arm Lower Handle	4			
20	229726	Bush Handle Pivot	4			
21	229736	Pivot Bolt	4			
22	B32902	Decal Dennis	1			
23	230035	Handle Lower 17" W.A.	1			
23	230020	Handle Lower 20" W.A.	1			
23	230030	Handle Lower 24" W.A.	1			
24	230040	Handle Upper W.A.	1			
25	230487	Micro Switch Bracket	1			
26	SP01070	Cap Head M2 x 12	1			
27	SP02032	Nut M2 STD	1			
28	SP012022	Electrical Loom Micro Switch	1			
29	SP01081	Cap Head M5 x 12	1			
30	J20110	Lever Grip	1			

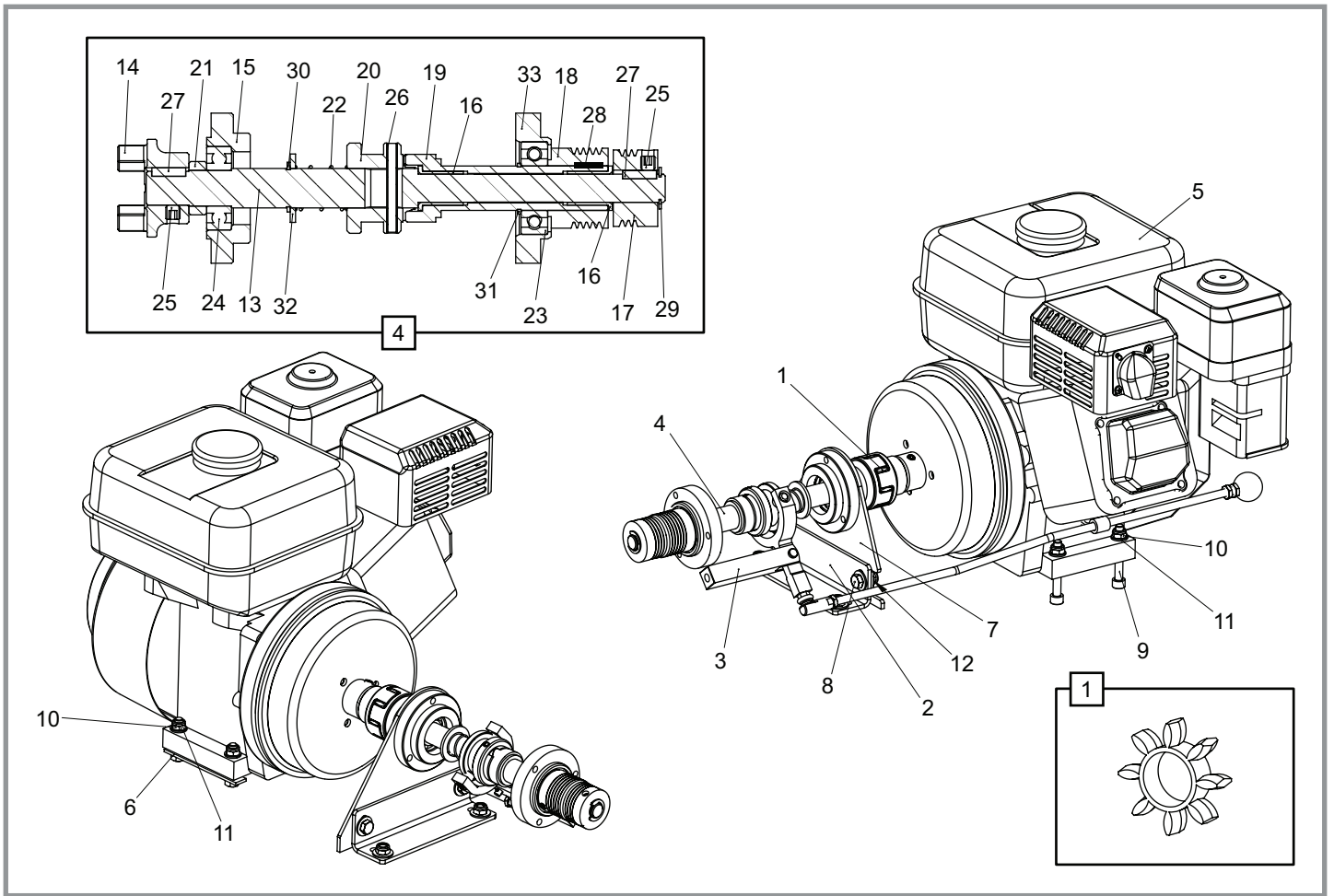

## 7.01

## Engine & Drive Kit - Main Assembly

Item No.	Part No.	Description	Quantity	Item No.	Part No.	Description	Quantity
1	228103	Coupling Element	1	28	J209029	Key 3/16" x 3/16" x 7/8" Rd End	1
2	230004	Support Bracket	1	29	J209106	E Clip 16mm	1
3	See 2.01	Cutter Engagment Assy (FT430)	1	30	228104	Circlip N1460-0087	1
3	See 2.01	Cutter Engagment Assy (FT510)	1	31	SP07007	Circlip D1460-25	1
3	See 2.01	Cutter Engagment Assy (FT610)	1	32	228106	Washer M22 Form A	1
4	800007	17" Top Drive Assembly	1	33	J209245	Top Drive Bearing Housing (FT430)	1
4	800016	20" Top Drive Assembly	1	33	J209211	Top Drive Bearing Housing (FT510 & 610)	1
4	800041	24" Top Drive Assembly	1				
5	800024	Engine Assembly	1	<b>Not Shown</b>			
6	J209050	Fixing Plate Assy	1	-	J209040	Bearing (6005) (FT430)	2
7	J179051	Support Plate (17")	1				
7	J209053	Support Plate (20" & 24")	1				
8	SP01009	Hex Set Screw M8 x 20	2				
9	SP01026	Cap Head M8 x 60	2				
10	SP02006	Nut M8 Nyloc	8				
11	SP03008	Washer M8 Form A	4				
12	SP03015	Washer M8 Form C	6				
13	J179240	Top Drive Shaft 17"	1				
13	J209240	Top Drive Shaft 20"	1				
13	J249240	Top Drive Shaft 24"	1				
14	228011	Coupling Half (3/4")	1				
15	J20051	Bearing Housing (6204) (FT510 & 610)	1				
16	J209039	Bush Flanged	2				
17	J209200	3 Groove Top Drive Pulley	1				
18	J209202	5 Groove Top Drive Pulley	1				
19	J209212	Inner Dog Tube	1				
19*	800217	Inner Dog Tube c/w Bushes	1				
20	J209214	Sliding Dog	1				
21	J209241	Bearing Spacer	1				
22	J209246	Top Drive Spring	1				
23	62662	Bearing 6205-2RS 3	1				
24	J20052	Bearing 6204-2RS 3	1				
25	J20467	Grub Screw M8 x 8	3				
26	J209104	Pin Spirol M6 x 50	1				
27	J209030	Key 3/16" x 3/16" x 3/4" Rd End	2				

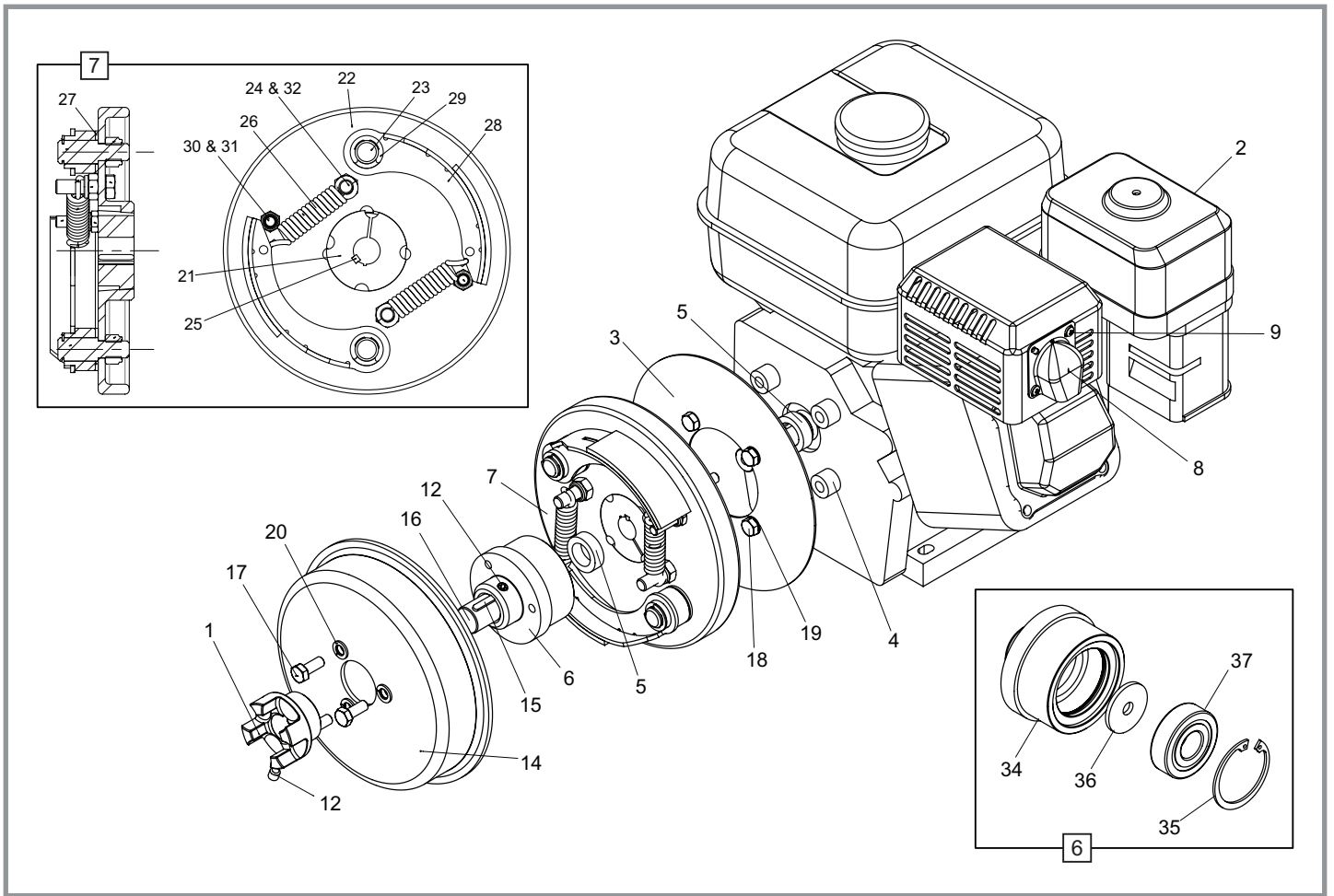

## 7.02

## Engine & Drive Kit - Centrifugal Clutch 06/2013 >

Item No.	Part No.	Description	Quantity	Item No.	Part No.	Description	Quantity
1	228102	Coupling Half (7/8")	1	34	230534	Bearing Hub Clutch	1
2	229901	Engine 5.5 Hp Honda Gx160 Q9	1	35	J209006	Circlip 47 M1308-0470	1
3	230530	Backing Plate Flywheel	1	36	J209249	Washer 9 X 35 X 3	1
4	230531	Spacer Back Plate	4	37	Sp06020	Bearing Rms6-2Rs	1
5	230535	Shaft Spacer	2				
6	800026	Clutch Hub Assembly	1				
7	800027	Fly Wheel Assembly	1				
8	J20367	Exhaust Deflector	1				
9	J20368	Screw M4 Exhaust Deflector	2				
10	J20369	E Clip 5Mm	1				
11	J20376	Throttle Clamp	1				
12	J20467	Grub Screw M8 X 8	2				
13	J209007	Cap Head 5/16" X 3/4"	1				
14	J209017	Clutch Drum Machined	1				
15	J209025	Key 3/16" X 3/16" X 1 3/4" Rd End	1				
16	J209233	Stub Shaft	1				
17	Sp01009	Hex Set Screw M8 X 20	3				
18	Sp01093	Hex Set Screw 5/16" Unf X 1"	4				
19	Sp03004	Washer M8 Toothed	4				
20	Sp03029	Washer M8 Spring Lock	3				
21	228001	Tapered Bush 1610 - 3/4"	1				
22	230532	Flywheel	1				
23	230533	Clutch Shoe Pivot	2				
24	E1-1119	Hex Set Screw M10 X 35	2				
25	J20457	Key 3/16" X 3/16" X 1" Rd End	1				
26	J209011	Tension Spring	2				
27	J209012	Washer M16 Form B	2				
28	J209013	Clutch Shoe Assy	2				
29	J209106	E Clip 16Mm	2				
30	Sp01036	Hex Set Screw M8 X 35	2				
31	Sp02006	Nut M8 Nyloc (T)	2				
32	Sp02008	Nut M10 Nyloc (T)	2				
33	Sp02010	Nut M12 Nyloc (T)	2				

**Note**  
For Throttle Cable, See Section 6.01

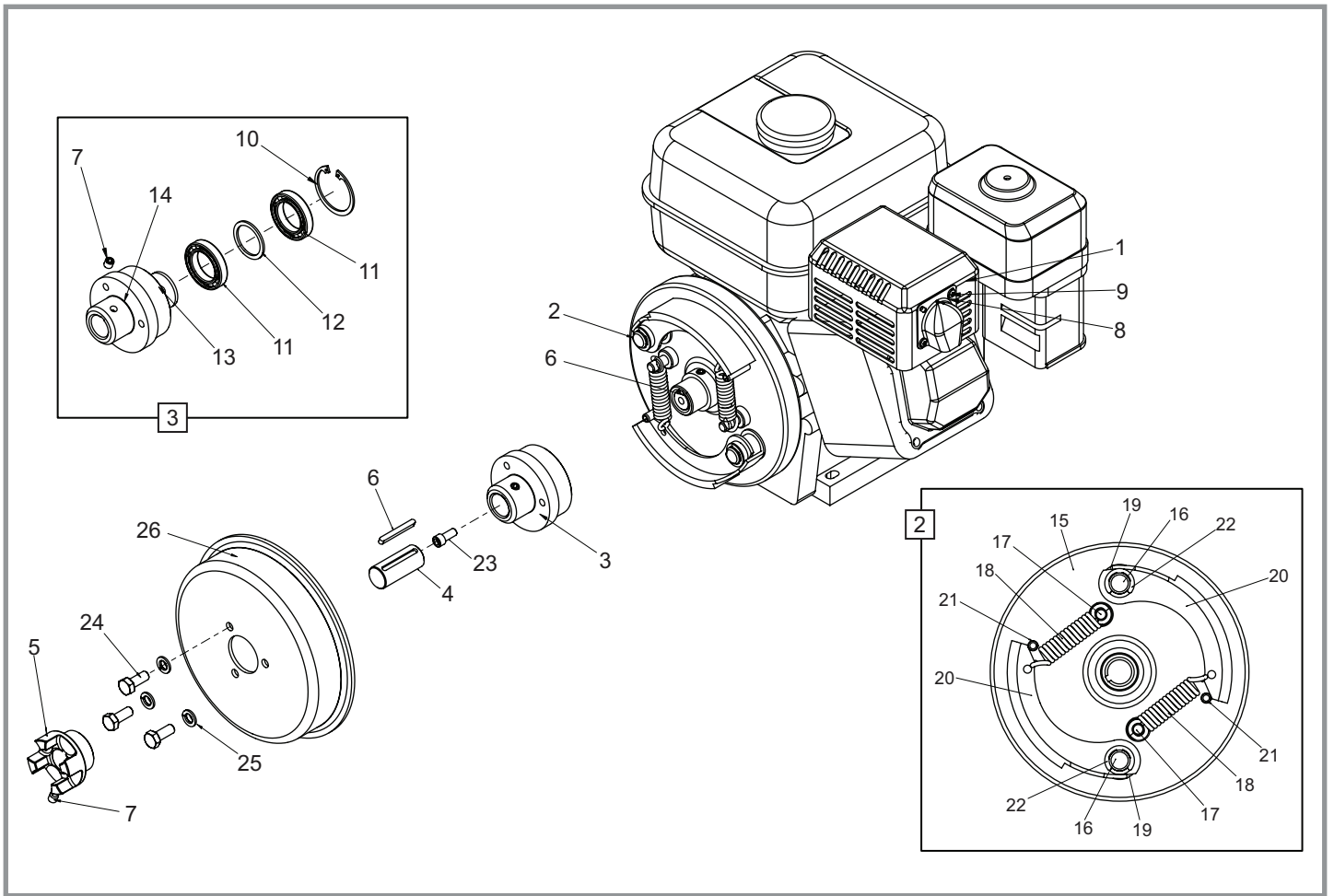

## 7.03

## Engine & Drive Kit - Centrifugal Clutch > 06/2013

Item No.	Part No.	Description	Quantity
1	229900	Engine (Honda GX120)	1
1	229901	Engine (Honda GX160)	1
2	800027	Flywheel Assembly	1
3	800026	Clutch Hub Assembly	1
4	J209233	Stub Shaft	1
5	228102	Coupling Shaft (7/8")	1
6	J209025	Key (3/16" x 3/16" x 1 3/4")	2
7	J20467	Grub Screw (M8 x 8)	3
8	J20367	Exhaust Deflector	1
9	J20368	Exhaust Deflector Screw (M4)	2
10	J209006	Circlip (47 M1308-0470)	1
11	J209247	Bearing 6906 2RS	2
12	J209248	Brg Spacer	1
13	J209249	Washer (9 x 35 x 3)	1
14	J209004	Bearing Hub Clutch	1
15	J209100	Flywheel	1
16	J209101	Clutch Shoe Pivot	2
17	J209102	Shoe Spring Anchor	2
18	J209011	Tension Spring	2
19	J209012	Washer M16 Form B	2
20	J209013	Brake Shoe	2
21	J209103	Pin Slotted (M8 x 50)	2
22	J209106	E Clip 16mm	2
23	J209007	Cap Screw	1
24	SP01009	Hex Set Screw M8 x 20	3
25	SP03029	Washer M8 Spring Lock	3
26	J209017	Clutch Drum	1

### NOTE

For Throttle Cable, see Section 6.01

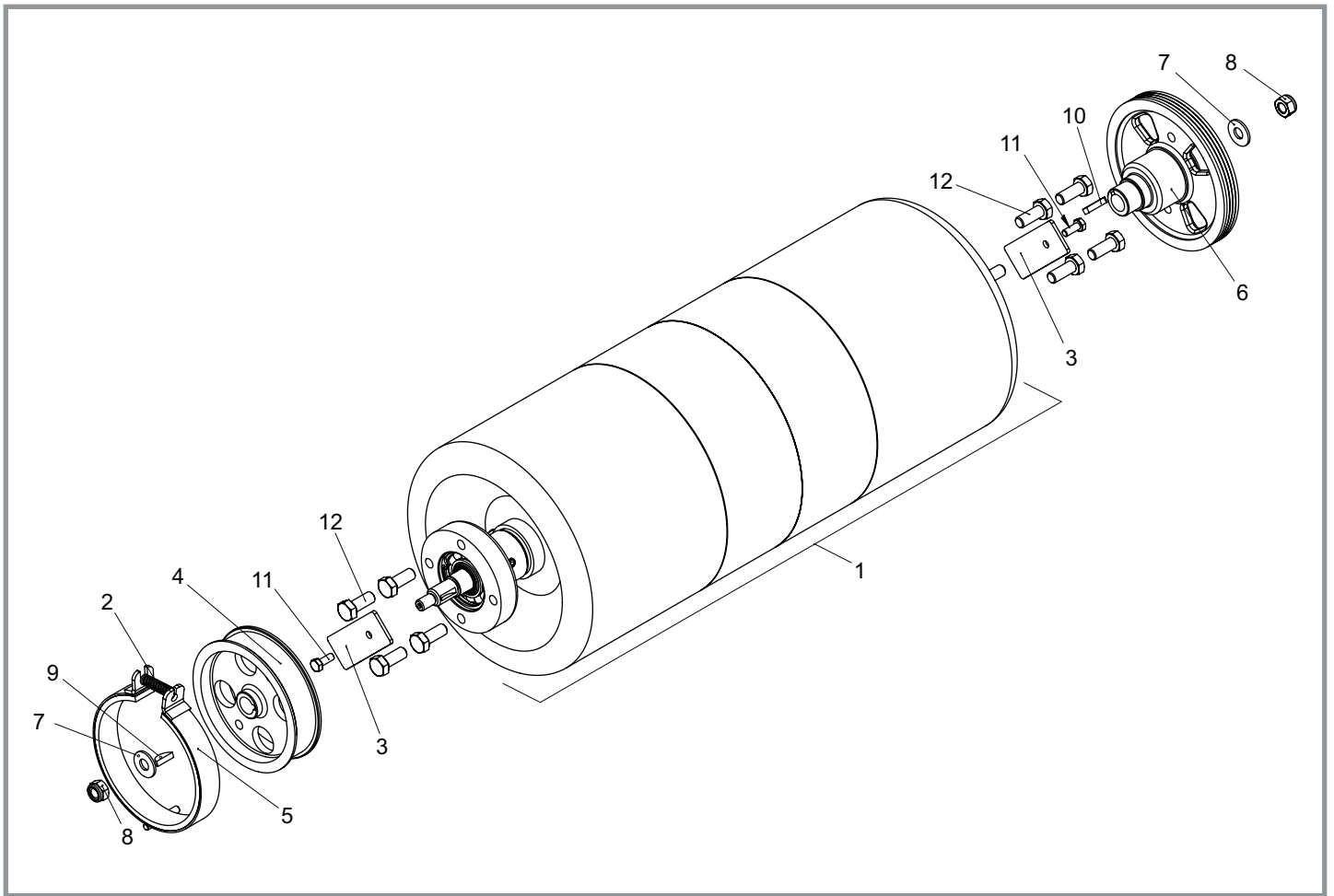

## 8.01

## Rear Roller - Main Assembly

Item No.	Description	Part Number	Quantity
1	See 8.02	Rear Roller Assy	1
2	J20119	Spring Scraper Brake Band	1
3	J20256	Roller Slot Cover Plate	2
4	J20461	Brake Drum	1
5	J20463	Brake Band Assy	1
6	J209201	Rear Roller Driven Pulley	1
7	SP03016	Washer M10 Form C	2
8	SP02008	Nut M10 Nyloc	2
9	J20462	Key Woodruff (606) 3/16" x 3/4"	1
10	J20457	Key 3/16" x 3/16" x 1" Rd End	1
11	SP01008	Hex Set Screw M6 x 16	2
12	SP01035	Hex Set Screw M10 x 25	8

### NOTE

For Brake Band Cable, see Section 6.01

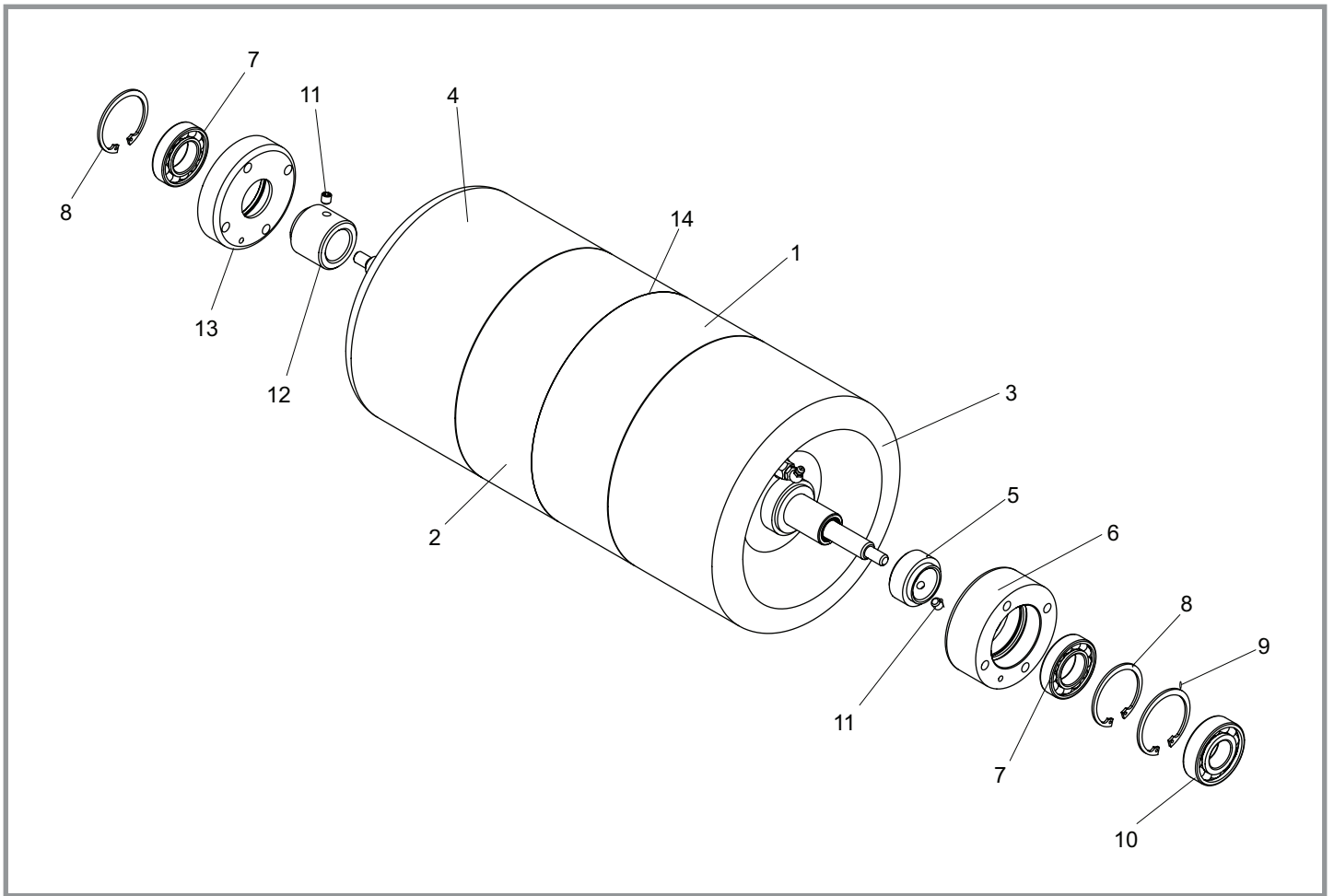

## 8.02

## Rear Roller - Roller Assembly

Item No.	Description	Part Number	Quantity
1	See 8.05	RH Differential Assy	
2	See 8.04	LH Differential Assy	
3	See 8.03	Outer Roller Assy	
4	See 8.03	Outer Roller Assy	
5	J20477	LH Spacer Collar	1
6	J20450	LH Bearing Housing	1
7	J20454	Bearing R18 2RS	2
8	J20475	Circlip Internal 54 x 2	2
9	J20474	Circlip Internal 57 x 2	1
10	J20455	Bearing RLS8 2RS	1
11	J20467	Grub Screw M8 x 8	2
12	J20464	RH Spacer Collar	1
13	J20453	RH Bearing Housing	1
14	J20494	Gasket Rear Roller	1

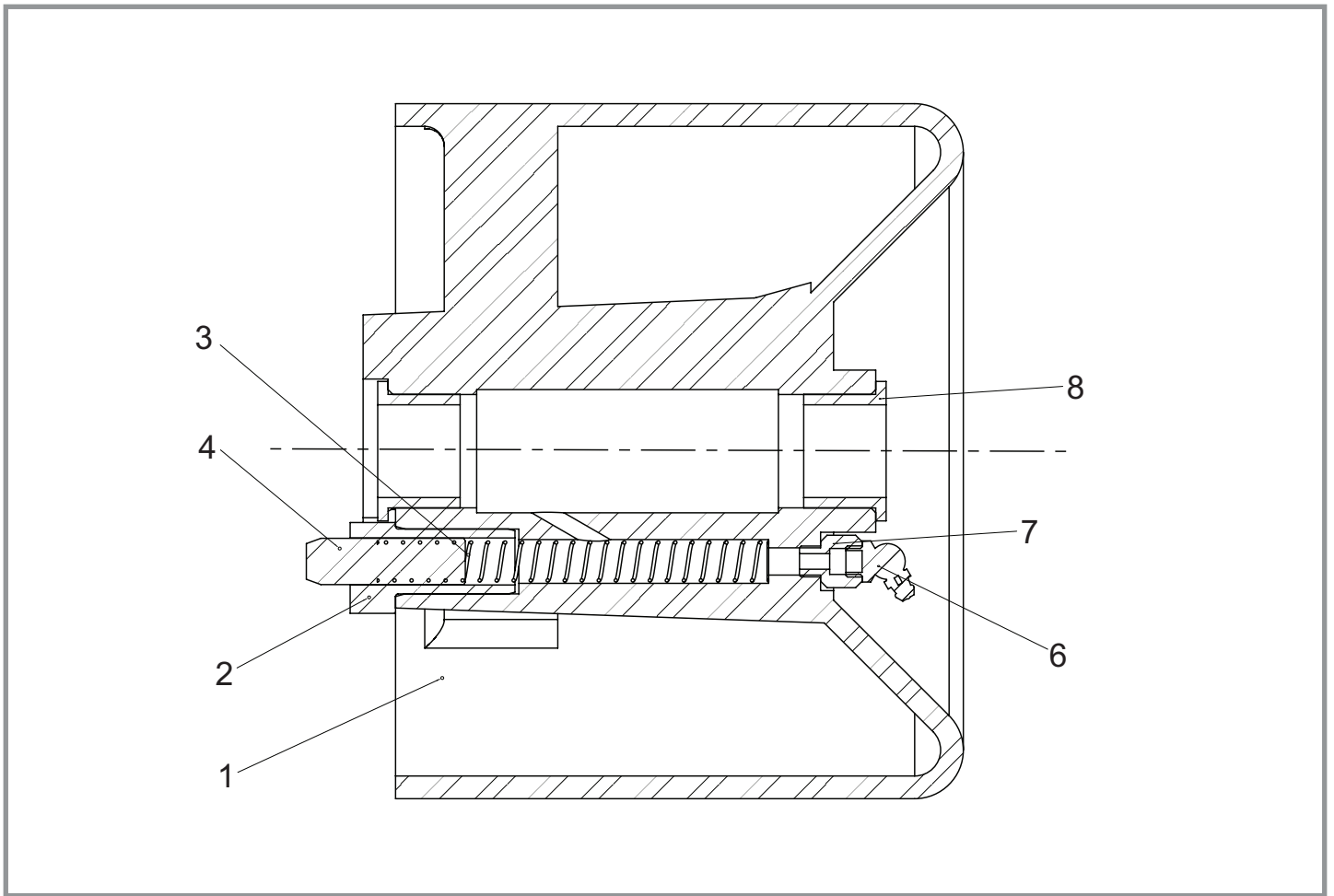

## 8.03

## Rear Roller - Outer Roller Assembly

Item No.	Part Number	Description	Quantity
1	J179540	17" LH Outer Roller c/w Bush	1
1	J179541	17" RH Outer Roller c/w Bush	1
1	800019L	20" LH Outer Roller c/w Bush	1
1	800019R	20" RH Outer Roller c/w Bush	1
1	800044L	24" LH Outer Roller c/w Bush	1
1	800044R	24" RH Outer Roller c/w Bush	1
2	J20476	Plunger Bush	1
3	J20435	Spring Plunger	1
4	J20437	Plunger Pawl	1
6	J20480	Grease Nipple 67 Deg 1/8" Bsp T	1
7	J20481	Grease Nipple Extension 1/8" Bsp T	1
8	J20473	Roller Bush	2

### Not Shown

-	J20404	Pin Spirol M5 x 24	1
---	--------	--------------------	---



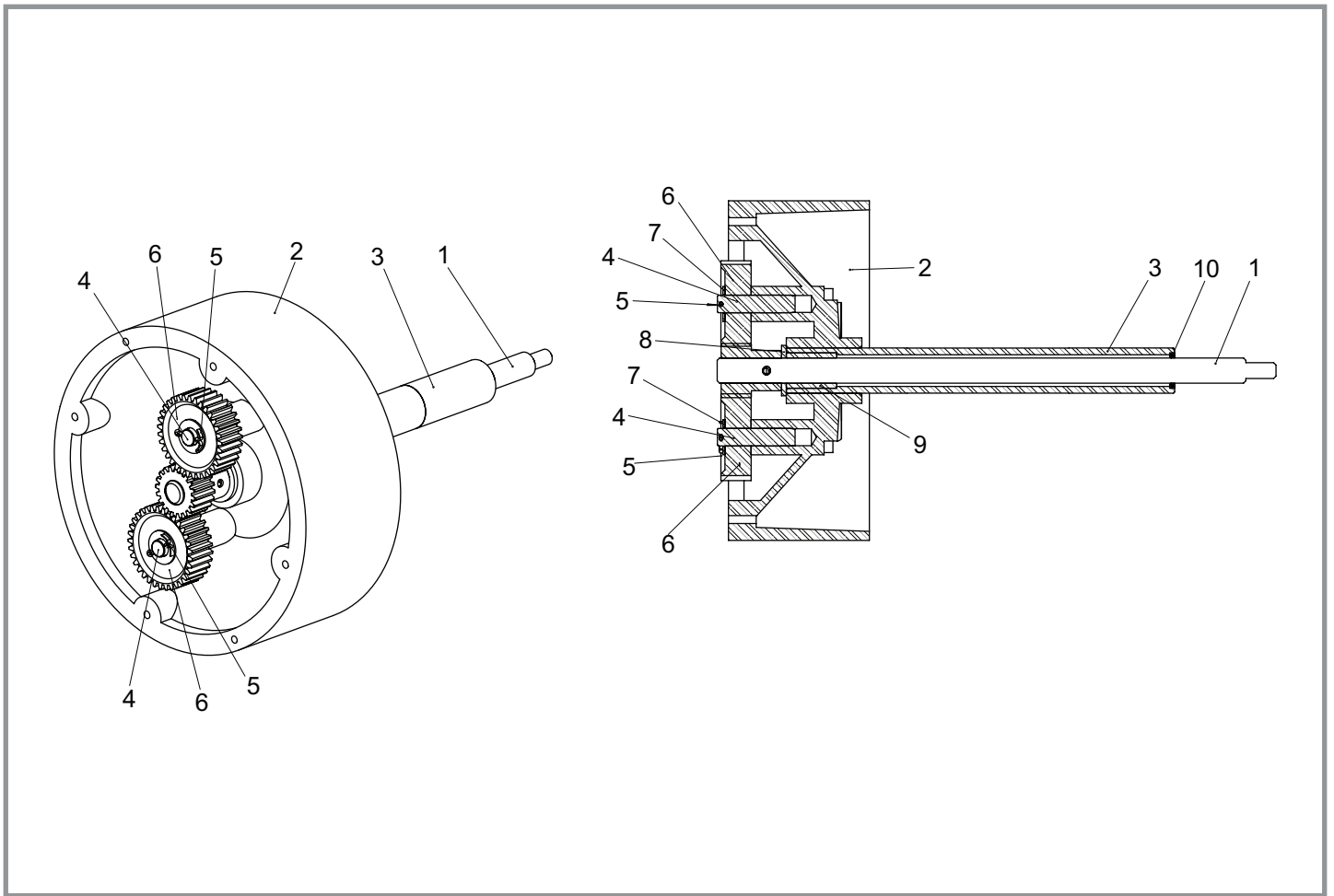

## 8.04

## Rear Roller - LH Differential Assembly

Item No.	Part No.	Description	Quantity
1	800005	Pinion Shaft Assy (FT430)	1
1	800014	Pinion Shaft Assy (FT510)	1
1	800039	Pinion Shaft Assy (FT610)	1
2	J20400	Planet Gear Case	1
3	J17401	17" Pinion Gear Case Tube	1
3	J20401	20" Pinion Gear Case Tube	1
3	J24401	24" Pinion Gear Case Tube	1
4	J20405	Planet Gear Pin	2
5	J20406	Split Pin 3/32" x 1"	2
6	J20407	Planet Gear (33t)	2
7	J20408	Washer Planet 7/16"	2
8	J20409	Pinion Washer	1
9	J20410	Pinion Gear Tube Bush	1
10	J20484	Seal Single Lip W087.62.12	1

### Not Shown

-	J20430	Caphead M6 x 30 (For Assy with 8.05)	4
-	J20494	Gasket Rear Roller (For Assy with 8.05)	1

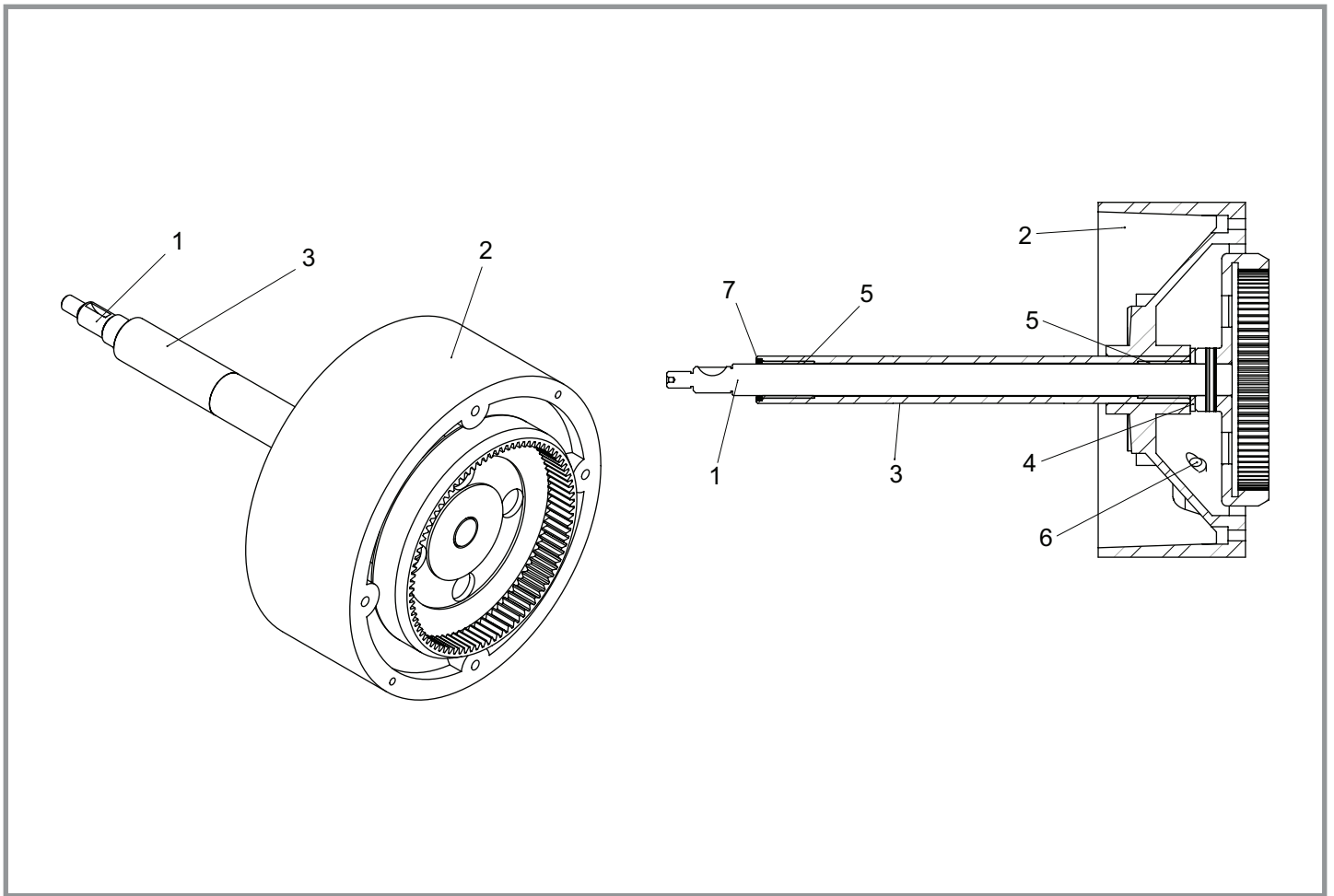

## 8.05

## Rear Roller - RH Differential Assembly

Item No.	Part No.	Description	Quantity
1	800006	17" Annular Gear Shaft Assy	1
1	800015	20" Annular Gear Shaft Assy	1
1	800040	24" Annular Gear Shaft Assy	1
2	J20420	Annular Gear Case	1
3	J17421	17" Annular Gear Case Tube	1
3	J20421	20" Annular Gear Case Tube	1
3	J24421	24" Annular Gear Case Tube	1
4	J20424	Washer Annular	1
5	J20426	Bush Annular Gear Tube	2
6	J20432	Oil Plug (14" BSP)	1
7	J20482	Seal Single Lip R21	1
<b>Not Shown</b>			
-	J20430	Caphead M6 x 30 (For Assy with 8.04)	4
-	J20494	Gasket Rear Roller (For Assy with 8.04)	1

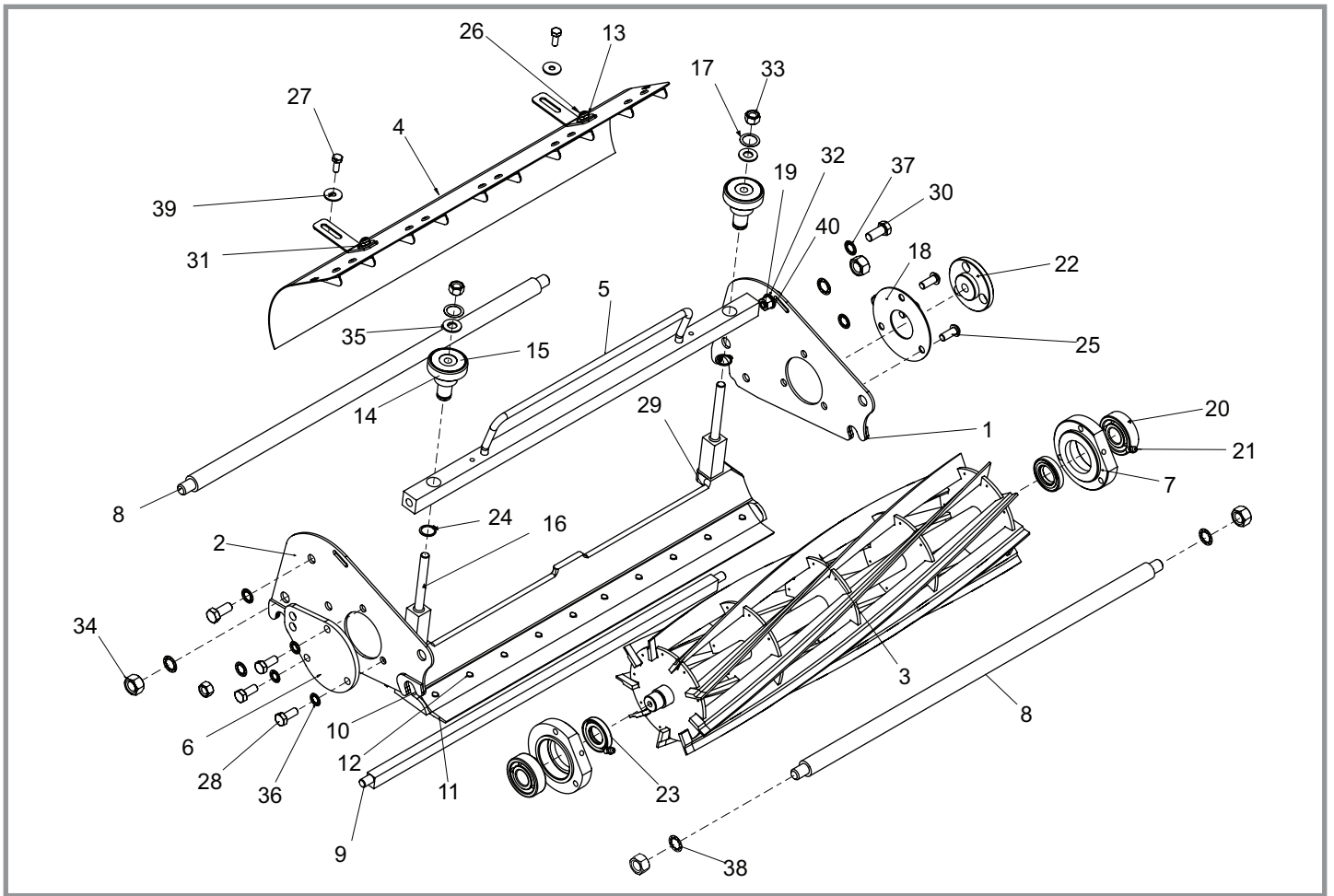

9.01

Cassette - Cutter

Item No.	Part No.	Description	Quantity	Item No.	Part No.	Description	Quantity
1	J19998	Cassette Side Plate W.A. L.H.	1	16	J209303	Adjuster Rod	2
2	J19999	Cassette Side Plate W.A. R.H.	1	17	J209304	Shim Od: 22 Id:16 THK 0.3	2
3	J17040	Cylinder 5 Blade 17"	1	18	J20008	Back Plate With Hole	1
3	J20040	Cylinder 5 Blade 20"	1	19	J20023	Unit Limiting Stud	1
3	J24040	Cylinder 5 Blade 24"	1	20	J20004	Bearing Self-aligning RI6	2
3	J17039	Cylinder 9 Blade 17"	1	21	J20064	Grease Nipple 1/4" UNF	2
3	J20039	Cylinder 9 Blade 20"	1	22	J20041	Female Coupling	1
3	J24039	Cylinder 9 Blade 24"	1	23	J20063	Seal Single Lip 22 x 40	2
4	J17033	Deflector Plate Assy 17" (Vane)	1	24	J209301	Circlip N1460 / 0062 (5/8 EXT)	2
4	J20033	Deflector Plate Assy 20" (Vane)	1	25	SP01006	Button Head M8 x 20	3
4	J24033	Deflector Plate Assy 24" (Vane)	1	26	SP01007	Coach Bolt M6	2
5	J179305	17" Shear Blade Adj Bar Assy	1	27	SP01008	Hex Set Screw M6 x 16	2
5	J209305	20" Shear Blade Adj Bar Assy	1	28	SP01009	Hex Set Screw M8 x 20	3
5	J249305	24" Shear Blade Adj Bar Assy	1	29	SP01010	Cap Head M10 x 30 (Low Hd)	2
6	J209076	Bearing Blank Plate	1	30	SP01011	Hex Set Screw 3/8" UNF x 3/4"	2
7	J20003	Cutter Bearing Housing	2	31	SP02004	Nut M6 Nyloc	2
8	J17011	17" Cassette Tie Bar	2	32	SP02005	Nut M8 STD	1
8	J20011	20" Cassette Tie Bar	2	33	SP02015	Nut 3/8" UNF	4
8	J24011	24" Cassette Tie Bar	2	34	SP02016	Nut 1/2" UNF	4
9	J17012	17" Rectangular Bar	1	35	SP03002	Washer 3/8"	4
9	J20012	20" Rectangular Bar	1	36	SP03004	Washer M8 Toothed	4
9	J24012	24" Rectangular Bar	1	37	SP03005	Washer M10 Toothed	4
10	J17025	Shear Blade Carrier 17"	1	38	SP03006	Washer M12 Toothed	4
10	J20025	Shear Blade Carrier 20"	1	39	SP03007	Washer M6 x 18	4
10	J24025	Shear Blade Carrier 24"	1	40	SP03008	Washer M8 Form A	1
11	J20065	Shear Blade 20" x 0.060"	1				
11	J24065	Shear Blade 24" x 0.060"	1				
11	J17030	Shear Blade 17" x 0.090"	1				
11	J20030	Shear Blade 20" x 0.090"	1				
11	J24030	Shear Blade 24" x 0.090"	1				
11	J20031	Lipped Blade 20"	1				
11	J24031	Lipped Blade 24"	1				
12	J20032	Screw Bottom Blade	8/10/12				
13	J209061	Deflector Bracket	2				
14	J209300	Adjuster Knob Cylinder	2				
15	J209302	Decal Cut On / Off	2				

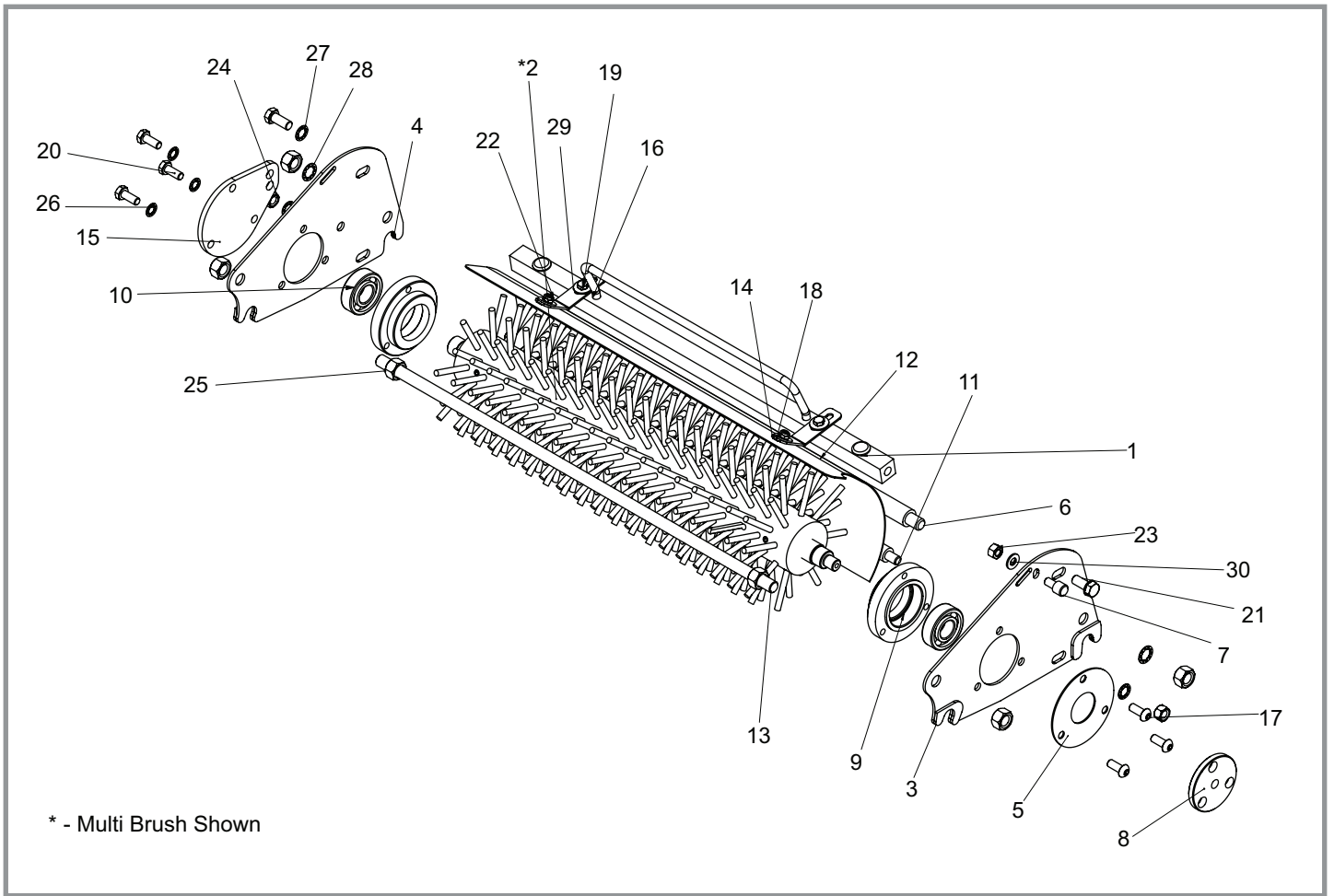

## 9.02

## Cassette - Brush

Item No.	Part No.	Description	Quantity	Item No.	Part No.	Description	Quantity
1	228062	3/4" Tube Bung (3132)	2	21	SP01011	Hex Set Screw (3/8" UNF x 3/4")	2
2	800174	Brush Shaft Assembly (17" Multi)	1	22	SP02004	Nut Nyloc (M6)	2
2	800186	Brush Shaft Assembly (20" Multi)	1	23	SP02005	Nut Std (M8)	1
2	800185	Brush Shaft Assembly (24" Multi)	1	24	SP02015	Nut (3/8" UNF)	2
2	800175	Brush Shaft Assembly (17" Standard)	1	25	SP02016	Nut (1/2" UNF)	6
2	800187	Brush Shaft Assembly (20" Standard)	1	26	SP03004	Washer (M8 Toothed)	4
2	800177	Brush Shaft Assembly (24" Standard)	1	27	SP03005	Washer (M10 Toothed)	4
3	J20001	Cassette Side Plate WA NC LH	1	28	SP03006	Washer (M12 Toothed)	2
4	J20002	Cassette Side Plate WA NC RH	1	29	SP03007	Washer (M6 x 18)	4
5	J20008	Back Plate With Hole	1	30	SP03008	Washer (M8 Form A)	1
6	J17011	Cassette Tie Bar (17")	1				
6	J20011	Cassette Tie Bar (20")	1				
6	J24011	Cassette Tie Bar (24")	1				
7	J20023	Unit Limiting Stud	1				
8	J20041	Female Coupling	1				
9	J20051	Bearing Housing (6204)	2				
10	J20052	Bearing 6204-2RS 3	2				
11	J17053	Tie Bar (17")	1				
11	J20053	Tie Bar (20")	1				
11	J24053	Tie Bar (24")	1				
12	J17054	Deflector Plate Assy (17")	1				
12	J20054	Deflector Plate Assy (20")	1				
12	J24054	Deflector Plate Assy (24")	1				
13	J17061	Front Tie Bar All Cassettes (17")	1				
13	J20061	Front Tie Bar All Cassettes (20")	1				
13	J24061	Front Tie Bar All Cassettes (24")	1				
14	J209061	Deflector Bracket	2				
15	J209076	Bearing Blank Plate	1				
16	J179305	Shear Blade Adj Bar Assy (17")	1				
16	J209305	Shear Blade Adj Bar Assy (20")	1				
16	J249305	Shear Blade Adj Bar Assy (24")	1				
17	SP01006	Button Head (M8 x 20)	3				
18	SP01007	Coach Bolt (M6)	2				
19	SP01008	Hex Set Screw (M6 x 16)	2				
20	SP01009	Hex Set Screw (M8 x 20)	3				

### NOTE

Multi Brush shown in diagram (Item 2)

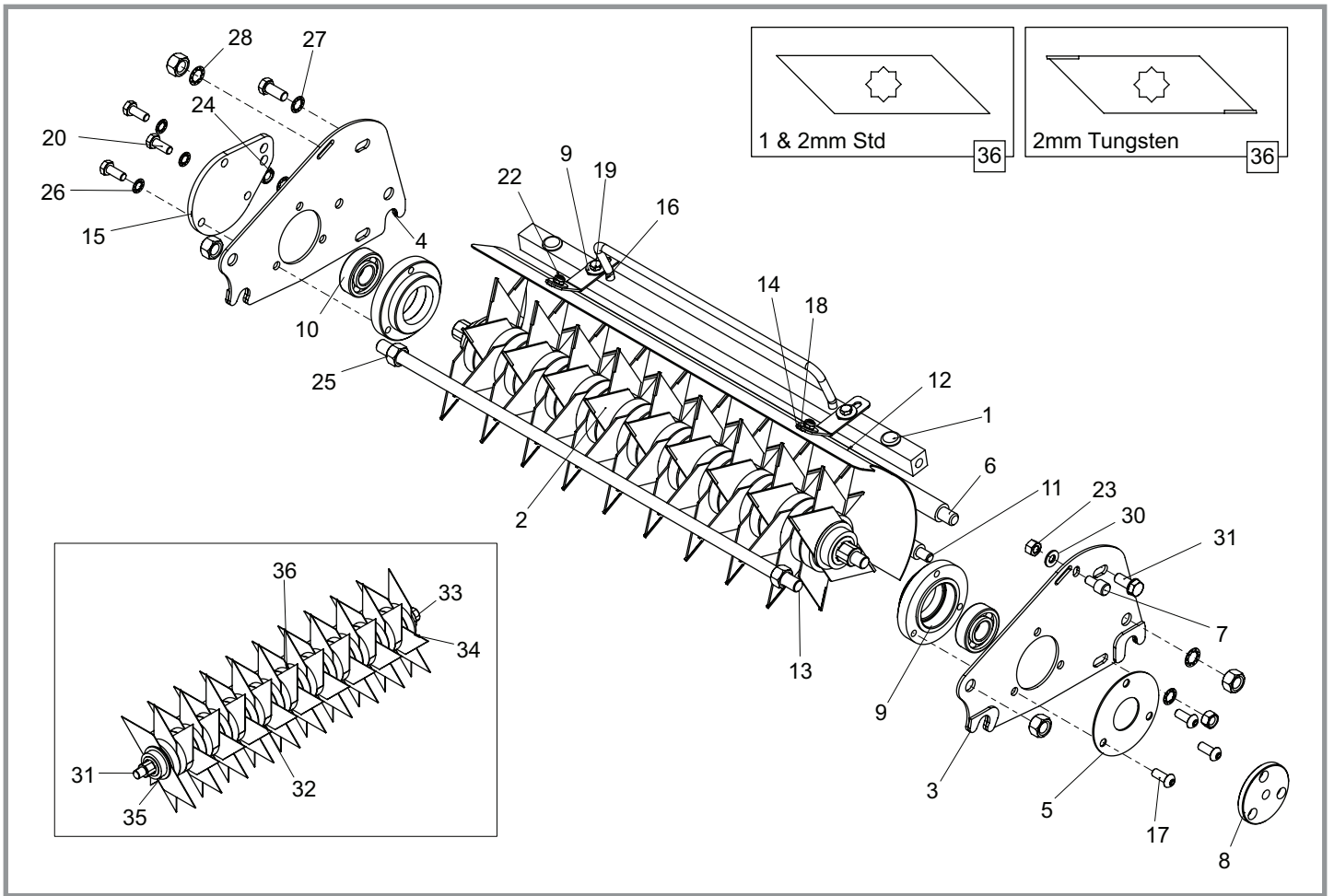

## 9.03

## Cassette - Scarifiers

Item No.	Part No.	Description	Quantity	Item No.	Part No.	Description	Quantity
1	228062	3/4" Tube Bung (3132)	2	19	SP01008	Hex Set Screw (M6 x 16)	2
2	800047	1mm Scarifier Hob Assy (17")	1	20	SP01009	Hex Set Screw (M8 x 20)	3
2	800052	1mm Scarifier Hob Assy (20")	1	21	SP01011	Hex Set Screw (3/8" UNF x 3/4")	2
2	800057	1mm Scarifier Hob Assy (24")	1	22	SP02004	Nut (M6 Nyloc)	2
2	800048	2mm Scarifier Hob Assy (17")	1	23	SP02005	Nut (M8 Std)	1
2	800053	2mm Scarifier Hob Assy (20")	1	24	SP02015	Nut (3/8" UNF)	2
2	800058	2mm Scarifier Hob Assy (24")	1	25	SP02016	Nut (1/2" UNF)	6
2	800207	2mm TT Scarifier Hob Assy (17")	1	26	SP03004	Washer (M8 Toothed)	4
2	800206	2mm TT Scarifier Hob Assy (20")	1	27	SP03005	Washer (M10 Toothed)	4
2	800208	2mm TT Scarifier Hob Assy (24")	1	28	SP03006	Washer (M12 Toothed)	2
3	J20001	Cassette Side Plate WA NC LH	1	29	SP03007	Washer (M6 x 18)	4
4	J20002	Cassette Side Plate WA NC RH	1	30	SP03008	Washer (M8 Form A)	1
5	J20008	Back Plate With Hole	1	31	J17055	Square Shaft (17")	1
6	J17011	Cassette Tie Bar (17")	1	31	J20055	Square Shaft (20")	1
6	J20011	Cassette Tie Bar (20")	1	31	J24055	Square Shaft (24")	1
6	J24011	Cassette Tie Bar (24")	1	32	J20056	Spacer	AR
7	J20023	Unit Limiting Stud	1	33	J20059	Nut 7/8" UNF Lock (Thin)	1
8	J20041	Female Coupling	1	34	J20060	Lock Washer (Small)	1
9	J20051	Bearing Housing (6204)	2	35	J209080	Flange Stop	1
10	J20052	Bearing 6204-2RS 3	2	36	J20058	Scarifer Blade 1mm	AR
11	J17053	Tie Bar (17")	1	36	J20057	Scarifer Blade 2mm	AR
11	J20053	Tie Bar (20")	1	36	230105	Scarifer Blade TT	AR
11	J24053	Tie Bar (24")	1				
12	J17054	Deflector Plate Assy (17")	1				
12	J20054	Deflector Plate Assy (20")	1				
12	J24054	Deflector Plate Assy (24")	1				
13	J17061	Front Tie Bar All Cassettes (FT430)	1				
13	J20061	Front Tie Bar All Cassettes (FT510)	1				
13	J24061	Front Tie Bar All Cassettes (FT610)	1				
14	J209061	Deflector Bracket	2				
15	J209076	Bearing Blank Plate	1				
16	J179305	Shear Blade Adj Bar Assy (17")	1				
16	J209305	Shear Blade Adj Bar Assy (20")	1				
16	J249305	Shear Blade Adj Bar Assy (24")	1				
17	SP01006	Button Head (M8 x 20)	3				
18	SP01007	Coach Bolt (M6)	2				

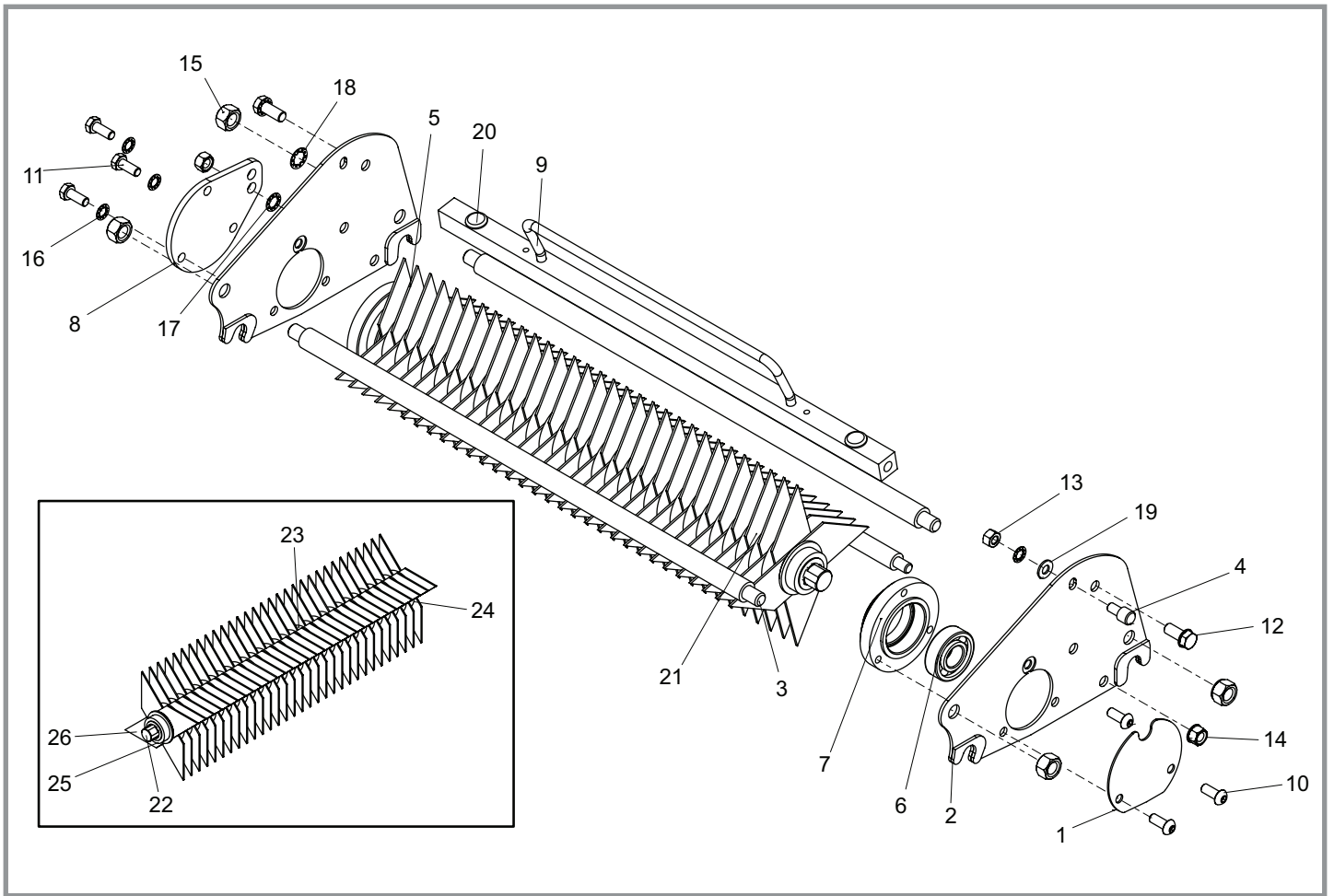

## 9.04

## Cassette - Slitter

Item No.	Part No.	Description	Quantity	Item No.	Part No.	Description	Quantity
1	230318	Blanking Plate	1	26	J20057	Scarifer Blade 2mm	AR
2	J20000	Cassette Side Plate WA ND	2	<b>Not Shown</b>			
3	J17011	Cassette Tie Bar (17")	2	-	J20059	Nut 7/8" UNF Lock (Thin)	1
3	J20011	Cassette Tie Bar (20")	2				
3	J24011	Cassette Tie Bar (24")	2				
4	J20023	Unit Limiting Stud	1				
5	J20051	Bearing Housing (6204)	2				
6	J20052	Bearing 6204-2RS 3	2				
7	J17053	Tie Bar (17")	1				
7	J20053	Tie Bar (20")	1				
7	J24053	Tie Bar (24")	1				
8	J209076	Bearing Blank Plate	1				
9	J179305	Shear Blade Adj Bar Assy (17")	1				
9	J209305	Shear Blade Adj Bar Assy (20")	1				
9	J249305	Shear Blade Adj Bar Assy (24")	1				
10	SP01006	Button Head (M8 x 20)	3				
11	SP01009	Hex Set Screw (M8 x 20)	3				
12	SP01011	Hex Set Screw (3/8" UNF x 3/4")	2				
13	SP02005	Nut (M8 Std)	1				
14	SP02015	Nut (3/8" UNF)	2				
15	SP02016	Nut (1/2" UNF)	4				
16	SP03004	Washer (M8 Toothed)	4				
17	SP03005	Washer (M10 Toothed)	4				
18	SP03006	Washer (M12 Toothed)	2				
19	SP03008	Washer (M8 Form A)	1				
20	228062	3/4" Tube Bung (3132)	2				
21	800051	Slitter Hob Assy (17")	1				
21	800056	Slitter Hob Assy (20")	1				
21	800061	Slitter Hob Assy (24")	1				
22	230334	Slitter Shaft FT (17")	1				
22	230335	Slitter Shaft FT (20")	1				
22	230336	Slitter Shaft FT (24")	1				
23	J20056	Spacer	AR				
24	J20060	Lock Washer (Small)	1				
25	J209080	Flange Stop	1				

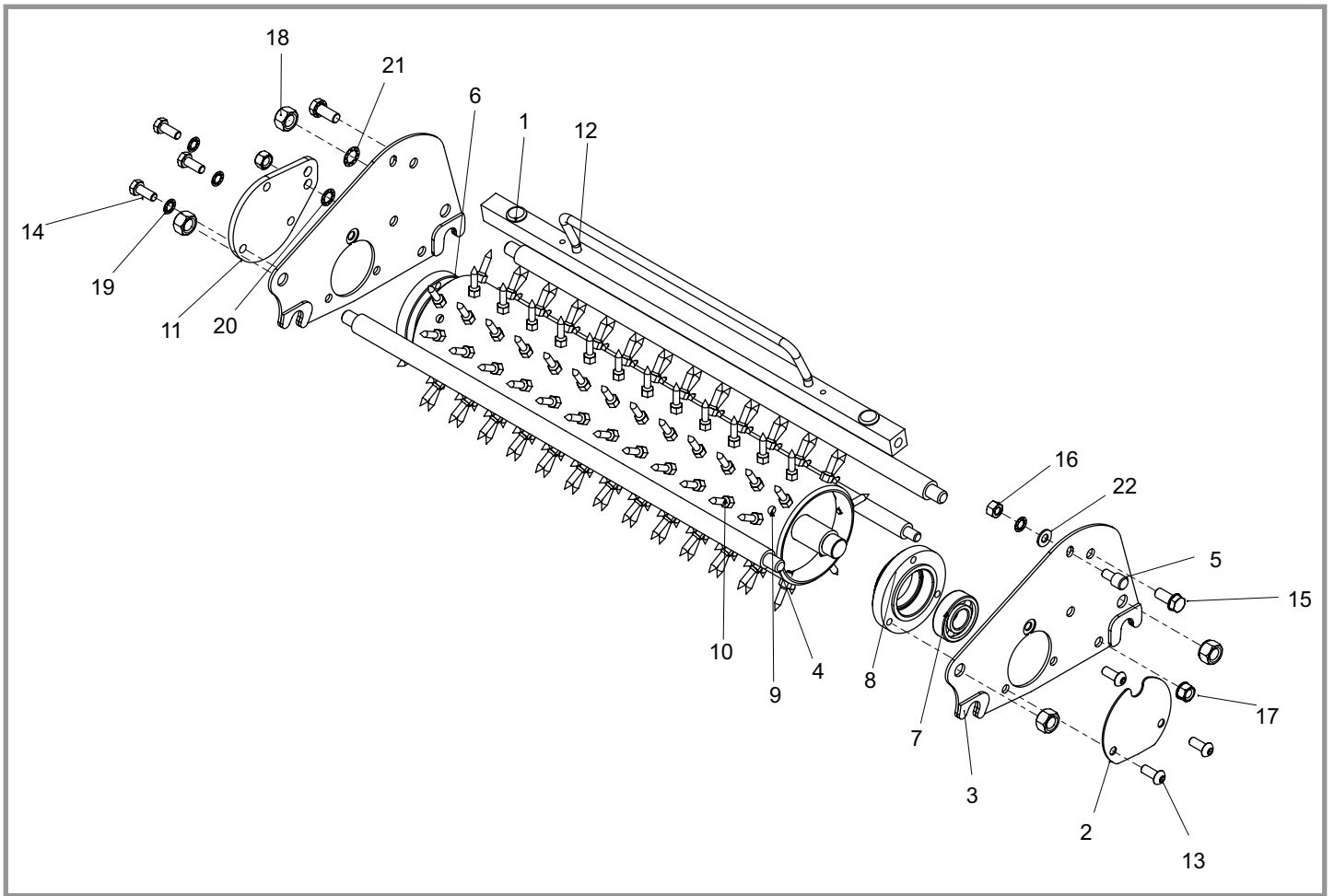

## 9.05

## Cassette - Sorrel

Item No.	Part No.	Description	Quantity
1	228062	3/4" Tube Bung (3132)	2
2	230318	Blanking Plate	1
3	J20000	Cassette Side Plate WA ND	2
4	J17011	Cassette Tie Bar (17")	2
4	J20011	Cassette Tie Bar (20")	2
4	J24011	Cassette Tie Bar (24")	2
5	J20023	Unit Limiting Stud	1
6	J20051	Bearing Housing (6204)	2
7	J20052	Bearing 6204-2RS 3	2
8	J17053	Tie Bar (17")	1
8	J20053	Tie Bar (20")	1
8	J24053	Tie Bar (24")	1
9	J17810	Sorrel Roller (17")	1
9	J20810	Sorrel Roller (20")	1
9	J24810	Sorrel Roller (24")	1
10	J20811	Spike Sorrel Roller	126/150/186
11	J209076	Bearing Blank Plate	1
12	J179305	Shear Blade Adj Bar Assy (17")	1
12	J209305	Shear Blade Adj Bar Assy (20")	1
12	J249305	Shear Blade Adj Bar Assy (24")	1
13	SP01006	Button Head (M8 x 20)	3
14	SP01009	Hex Set Screw (M8 x 20)	3
15	SP01011	Hex Set Screw (3/8" UNF x 3/4")	2
16	SP02005	Nut (M8 Std)	1
17	SP02015	Nut (3/8" UNF)	2
18	SP02016	Nut (1/2" UNF)	4
19	SP03004	Washer (M8 Toothed)	4
20	SP03005	Washer (M10 Toothed)	4
21	SP03006	Washer (M12 Toothed)	2
22	SP03008	Washer (M8 Form A)	1

### Not Shown

-	J17816	Weight Bar 17"	1
-	J20816	Weight Bar 20"	1
-	J24816	Weight Bar 24"	1

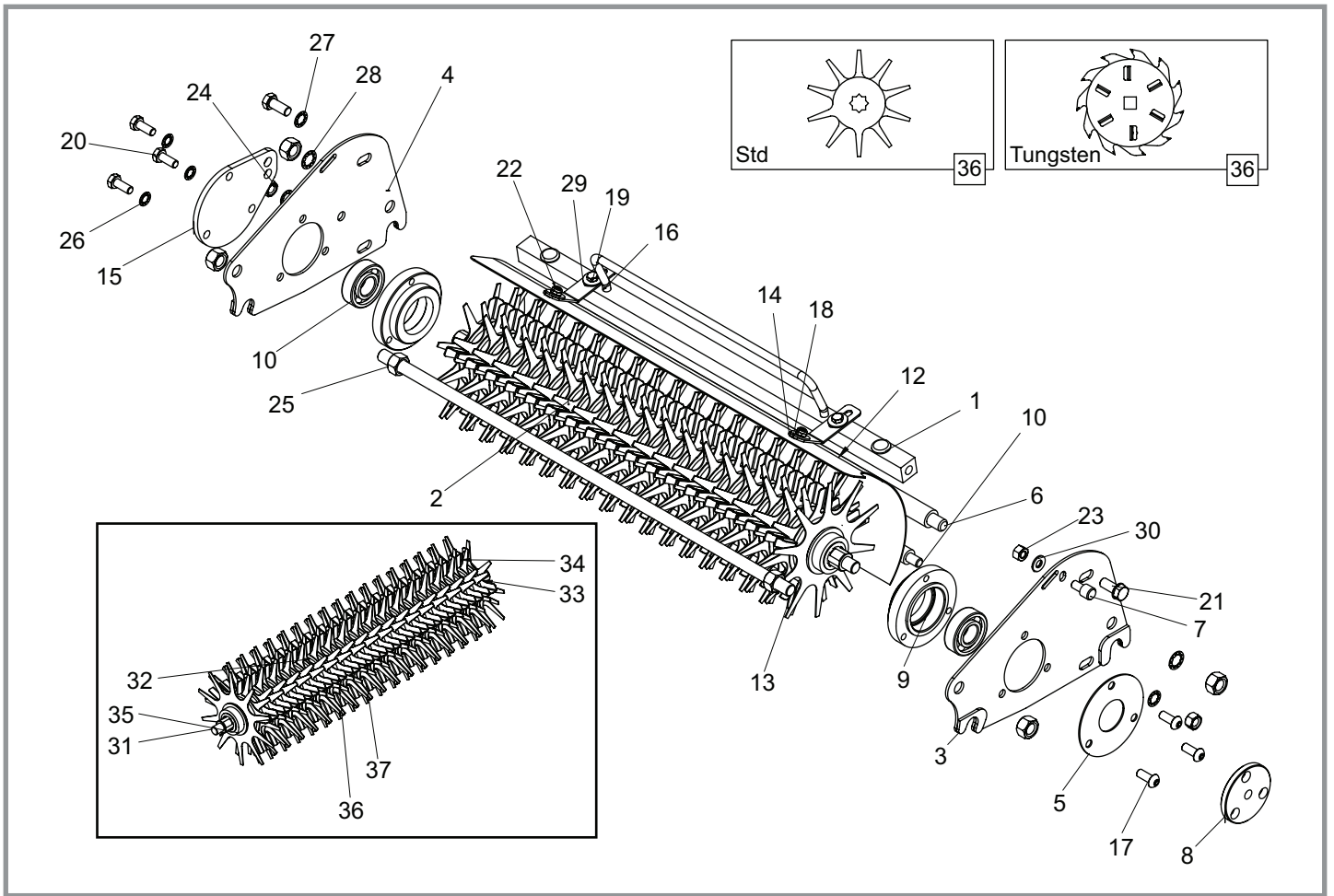

## 9.06

## Cassette - Verticutters

Item No.	Part No.	Description	Quantity	Item No.	Part No.	Description	Quantity
1	228062	3/4" Tube Bung (3132)	2	25	SP02016	Nut (1/2" UNF)	6
2	800049	Verticutter Hob Assy (17")	1	26	SP03004	Washer (M8 Toothed)	4
2	800054	Verticutter Hob Assy (20")	1	27	SP03005	Washer (M10 Toothed)	4
2	800059	Verticutter Hob Assy (24")	1	28	SP03006	Washer (M12 Toothed)	2
2	800050	Tungsten Verticutter Hob Assy (17")	1	29	SP03007	Washer (M6 x 18)	4
2	800055	Tungsten Verticutter Hob Assy (20")	1	30	SP03008	Washer (M8 Form A)	1
2	800060	Tungsten Verticutter Hob Assy (24")	1	31	J17055	Square Shaft (17")	1
3	J20001	Cassette Side Plate WA NC LH	1	31	J20055	Square Shaft (20")	1
4	J20002	Cassette Side Plate WA NC RH	1	31	J24055	Square Shaft (24")	1
5	J20008	Back Plate With Hole	1	32	J20056	Spacer	AR
6	J17011	Cassette Tie Bar (17")	1	33	J20059	Nut 7/8" UNF Lock (Thin)	1
6	J20011	Cassette Tie Bar (20")	1	34	J20060	Lock Washer (Small)	1
6	J24011	Cassette Tie Bar (24")	1	35	J209080	Flange Stop	1
7	J20023	Unit Limiting Stud	1	36	J20072	Dethatcher Blade	AR
8	J20041	Female Coupling	1	36	229538	Tungsten Tipped Blade 11T	AR
9	J20051	Bearing Housing (6204)	2	37	229533	Fan Blade Small	AR
10	J20052	Bearing 6204-2RS 3	2				
11	J20053	Tie Bar (20")	1				
12	J20054	Deflector Plate Assy (20")	1				
13	J17061	Front Tie Bar All Cassettes (FT430)	1				
13	J20061	Front Tie Bar All Cassettes (FT510)	1				
13	J24061	Front Tie Bar All Cassettes (FT610)	1				
14	J209061	Deflector Bracket	2				
15	J209076	Bearing Blank Plate	1				
16	J179305	Shear Blade Adj Bar Assy (17")	1				
16	J209305	Shear Blade Adj Bar Assy (20")	1				
16	J249305	Shear Blade Adj Bar Assy (24")	1				
17	SP01006	Button Head (M8 x 20)	3				
18	SP01007	Coach Bolt (M6)	2				
19	SP01008	Hex Set Screw (M6 x 16)	2				
20	SP01009	Hex Set Screw (M8 x 20)	3				
21	SP01011	Hex Set Screw (3/8" UNF x 3/4")	2				
22	SP02004	Nut (M6 Nyloc)	2				
23	SP02005	Nut (M8 Std)	1				
24	SP02015	Nut (3/8" UNF)	2				

### NOTE

Item 37 is not required on Tungsten Tipped option.



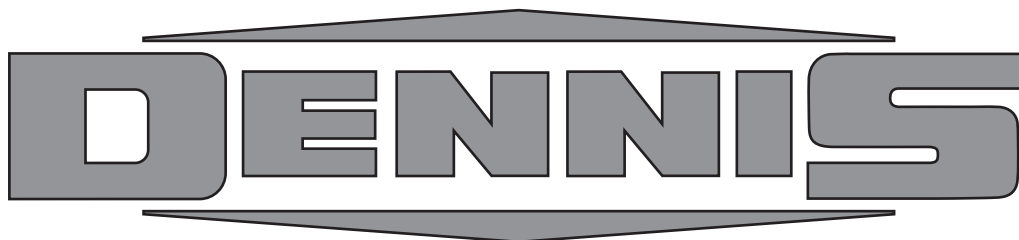

**DENNIS**, Ashbourne Road, Kirk Langley, Derby, DE6 4NJ, United Kingdom

**Telephone:-** 01332 824777

**Fax:-** 01332 824 525

**E-mail:-** sales@dennisuk.com

**E-mail:-** spares@dennisuk.com

[www.dennisuk.com](http://www.dennisuk.com)